



G300/G330 BARCODE PRINTER USER MANUAL



CONTENTS

1	Barcode Printer	001
1.1	Box Content	001
1.2	Getting To Know Your Printer	002
2	Printer Setup	004
2.1	Open The Printer Cover	004
2.2	Open The Printing Mechanism	004
2.3	Loading The Ribbon	005
2.4	Loading The Label Roll	009
2.5	Installing The Label Supply Hub	012
2.6	Connecting The Printer To The Host Computer	013
2.7	Installing The Driver	015
3	Operation Panel	018
3.1	LED Operation Panel	018
3.2	Error Alerts	019
3.3	Label Calibration and Self Test Page	020
4	NetSetting For Ethernet	021
4.1	Installing The NetSetting Software	021
4.2	The Interface of NetSetting	022
5	Maintenance and Adjustment	029
5.1	Cleaning The Print Head	029
5.2	Adjusting The Print Head Pressure	030
5.3	Adjusting The Print Line	031
5.4	Troubleshooting	032
	Appendix	
	Product Specifications	
	Interface	

FCC COMPLIANCE STATEMENT FOR AMERICAN USERS

This equipment has been tested and found to comply with the limits for a CLASS A digital device, pursuant to Part 15 of the FCC Rules. These limits are designed to provide reasonable protection against harmful interference when the equipment is operated in a commercial environment. This equipment generates, uses, and can radiate radio frequency energy and, if not installed and used in accordance with the instructions, may cause harmful interference to radio communications. Operation of this equipment in a residential area is likely to cause harmful interference in which case the user will be required to correct the interference at own expense.

EMS AND EMI COMPLIANCE STATEMENT FOR EUROPEAN USERS

This equipment has been tested and passed with the requirements relating to electromagnetic compatibility based on the standards EN 55022:1998+A1:2000+A2:2003, CISPR 22, Class A EN 55024: 1998+A1: 2001+A2: 2003, IEC 61000-4 Series EN 61000-3-2/2000&EN 61000-3-3/1995. The equipment also tested and passed in accordance with the European Standard EN55022 for the both Radiated and Conducted emissions limits.

G300 SERIES TO WHICH THIS DECLARATION RELATES IS IN CONFORMITY WITH THE FOLLOWING STANDARDS

EN55022: 1998, CISPR 22, Class A/EN55024: 1998/IEC 61000-4 Serial/EN61000-3-2: 2000/EN 6100-3-3: 1995/CFR 47, Part 15/CISPR 22 3rd Edition: 1997, Class A/ANSI C63.4: 2001/CNS 13438/IEC60950-1: 2005 (EN 60950-1: 2006+A11: 2009)/ GB4943: 2001/ GB9254: 1998/GB17625.1: 2003/EN60950-1: 2001

Caution

- * Danger of explosion if battery is incorrectly replaced. Replace only with the equivalent type recommended by the manufacturer.
- ** Dispose of used batteries according to the manufacturer's instructions.
- *** Only use with designated power supply adapter model.
- **** Changes or modifications not expressly approved by the party responsible for compliance could void the user's authority to operate the equipment.

SAFETY INSTRUCTIONS

Please read the following instructions carefully.

1. Keep the equipment away from humidity.
2. Before you connect the equipment to the power outlet, please check the voltage of the power source.
3. Make sure the printer is off before plugging the power connector into the power jack.
4. It is recommended that you connect the printer to a surge protector to prevent possible transient overvoltage damage.
5. Be careful not to get liquid on the equipment to avoid electrical shock.
6. For safety and warranty reasons, ONLY qualified service personnel should open the equipment.
7. Do not repair or adjust energized equipment under any circumstances.

1 Barcode Printer

1.1 Box Content

Please check that all of the following items are included with your printer.

- G300 Barcode Printer

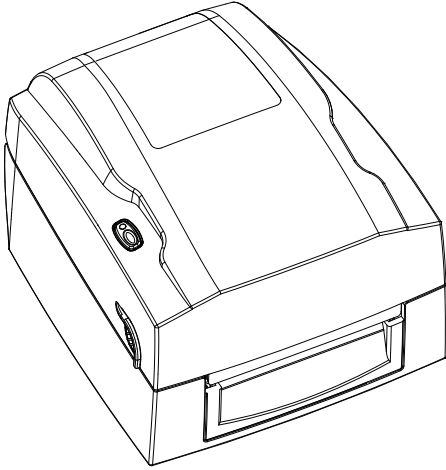

- Label Supply Module
Label Supply Hub

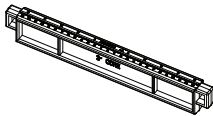

Label Guide Plates (Set of 2)

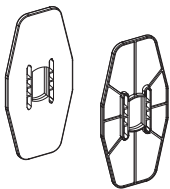

Label Stock

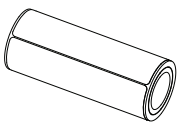

- USB Cable

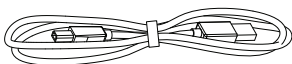

- Ribbon Module
Empty Ribbon Core



Ribbon

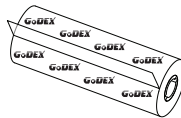

- Power Adapter
Power Cord

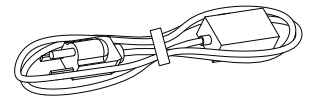

AC Adapter

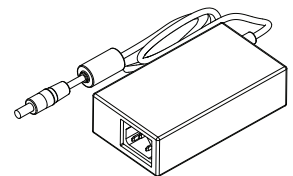

- CD
Including QLabel software
and G300 user manual.



- G300 Quick Guide



1 Barcode Printer

1.2 Getting To Know Your Printer

Device Overview

- Front View

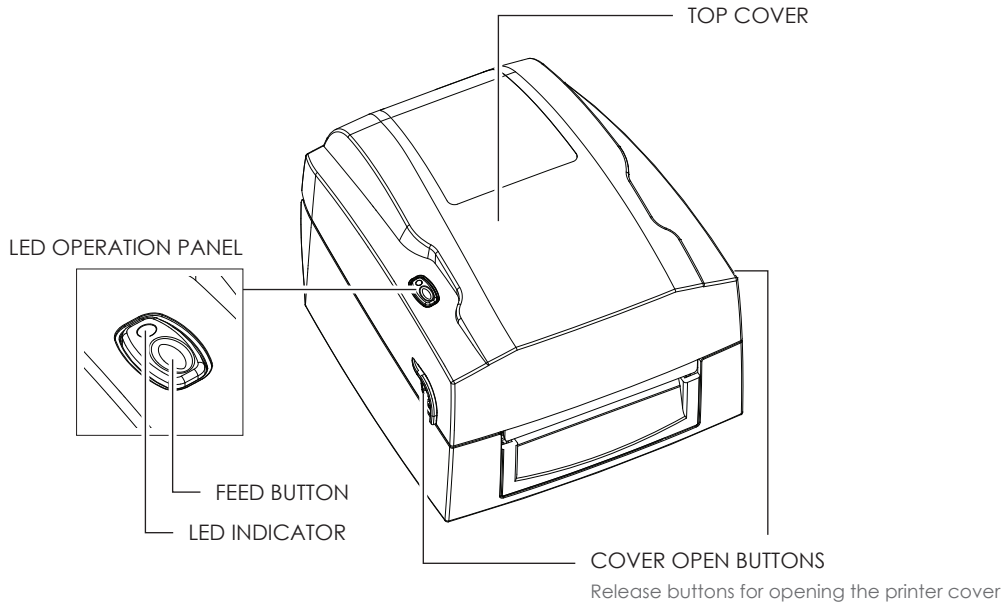

- Rear View

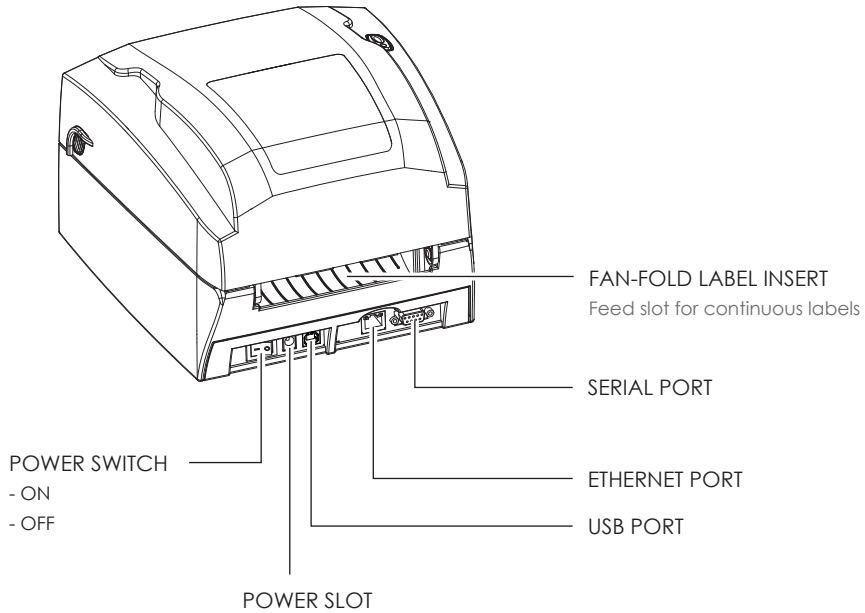

1 Barcode Printer

Open The Printer Cover

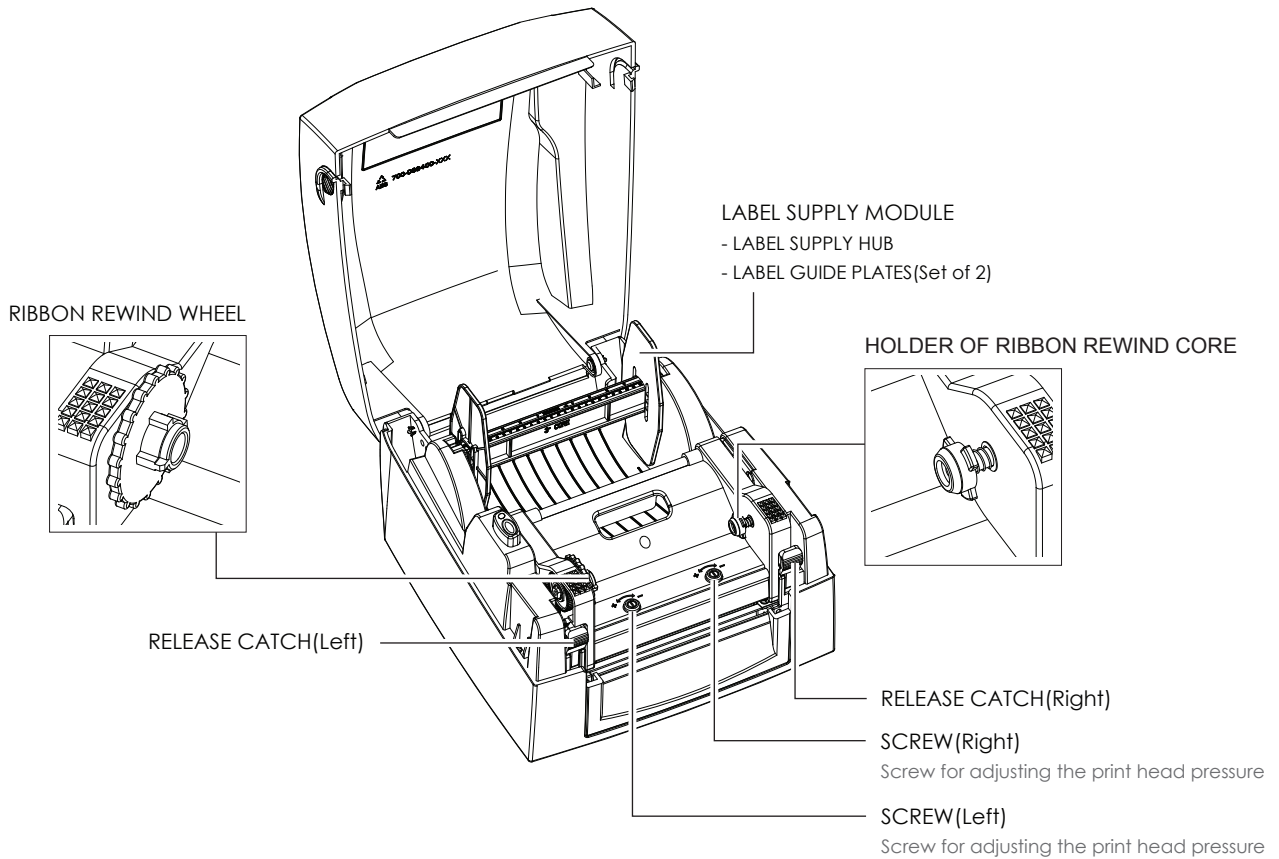

Open The Printing Mechanism

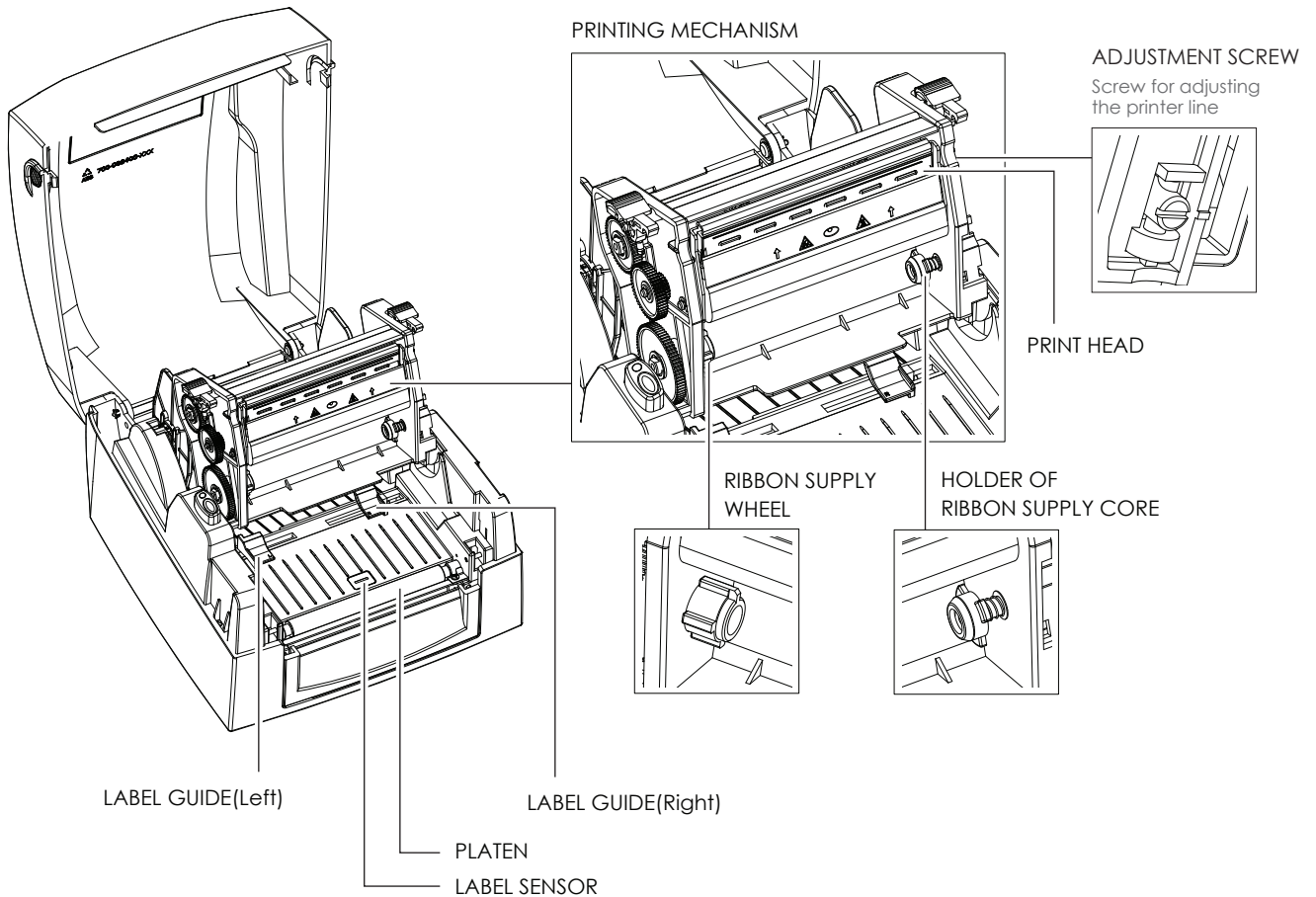

2 Printer Setup

2.1 Open The Printer Cover

Pressing The Cover Open Buttons

Place the printer on a flat surface. Open the printer cover by pressing the release buttons on both sides of the printer housing and lift the cover.

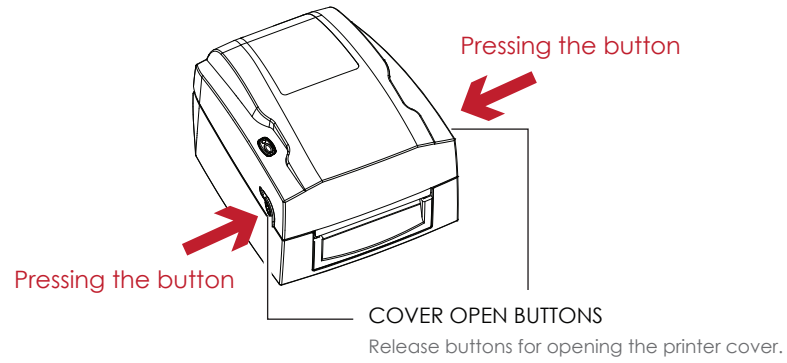

Lift the printer cover backward

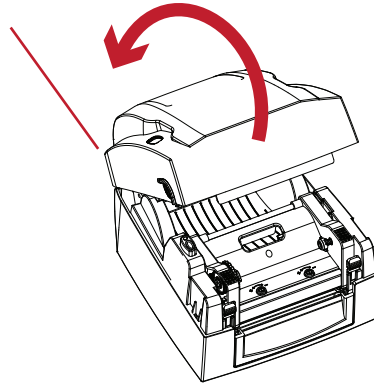

2.2 Open The Printing Mechanism

Pressing The Release Catches

Release and lift the printing mechanism.

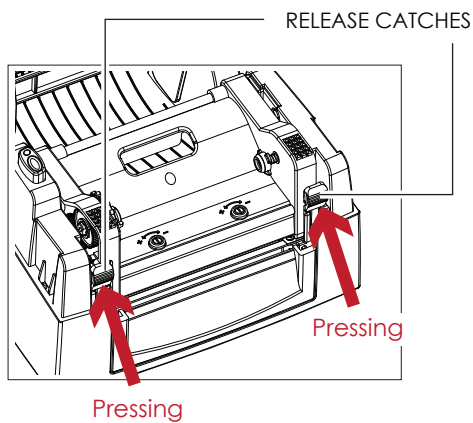

Lift the printing mechanism

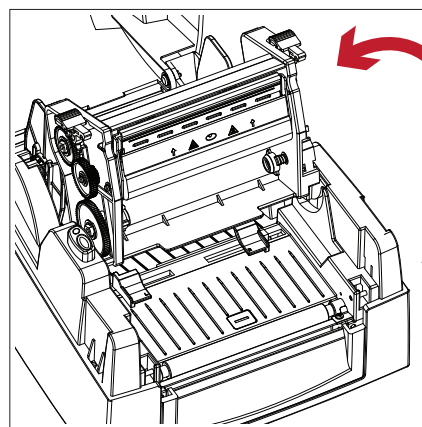

2 Printer Setup

2.3 Loading The Ribbon

A New Ribbon Module Installation

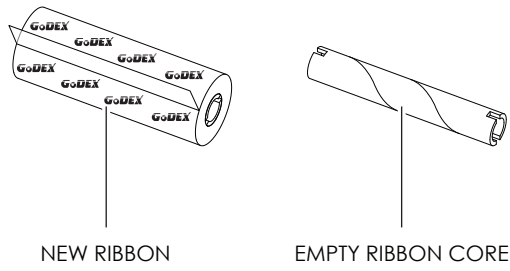

1. Attach the ribbon to the empty ribbon core with the adhesive strip at the end of the ribbon.

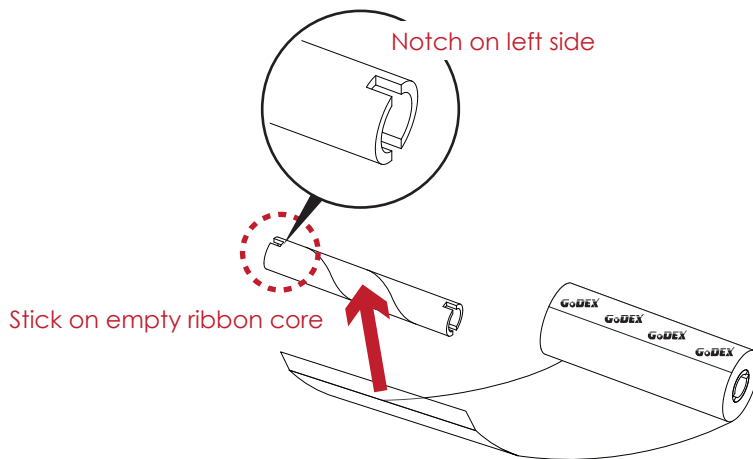

2. Wind the ribbon around the empty ribbon core for 2 to 3 circles.

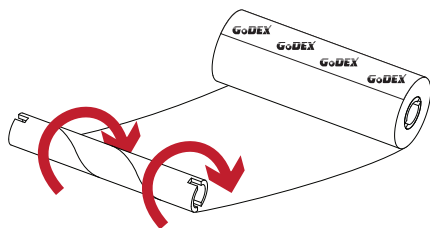

3. A ribbon module is assembled as below.

A NEW RIBBON MODULE

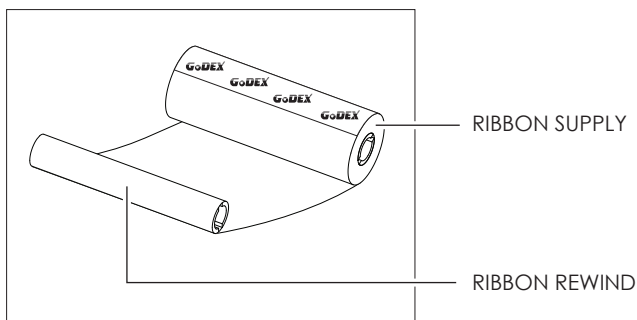

2 Printer Setup

Load The Ribbon On The Printer For Ribbon Supply Module

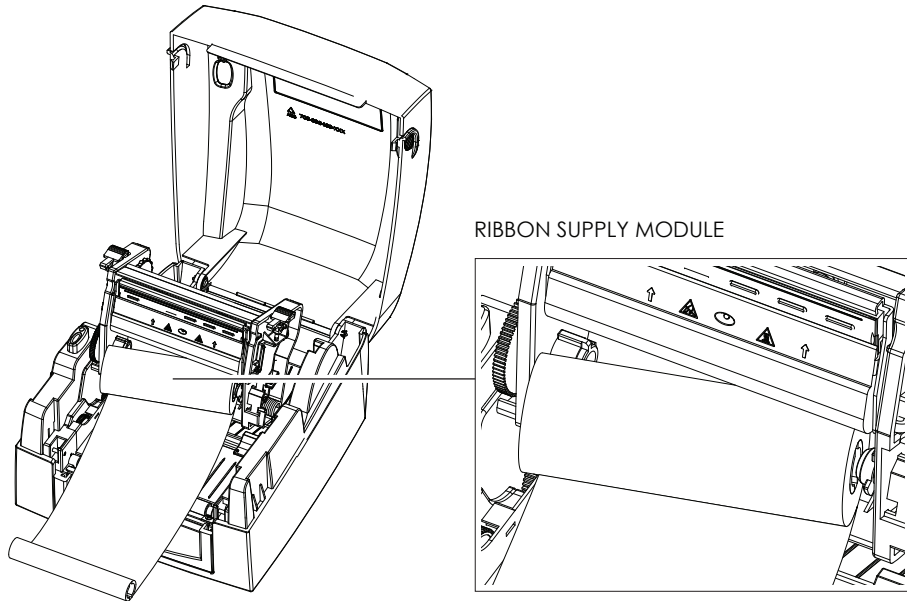

1. Place the right-hand side of ribbon first.

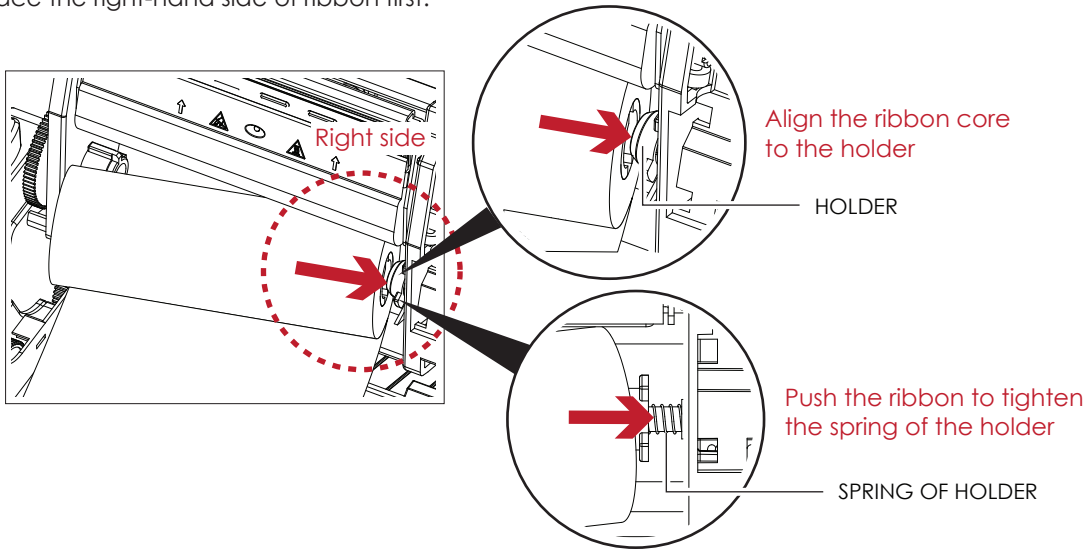

2. Then place the left-hand side of the ribbon.

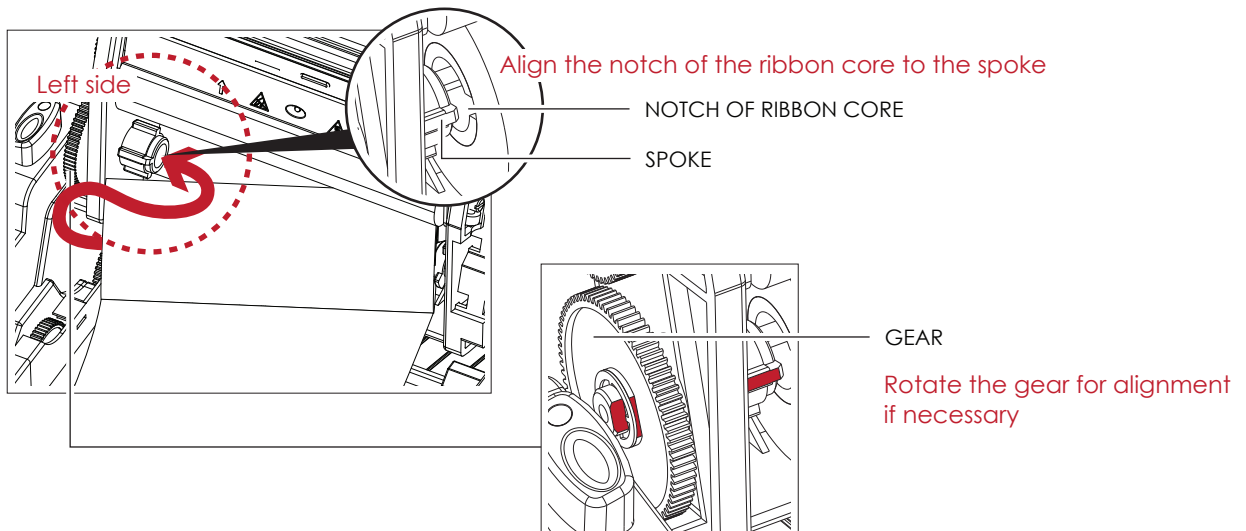

2 Printer Setup

3. Close the printing mechanism to complete the ribbon supply module loading.

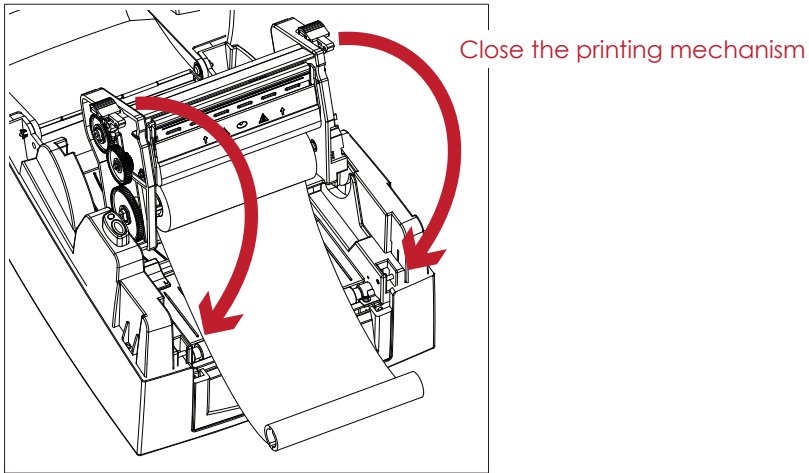

Load The Ribbon On The Printer For Ribbon Rewind Module

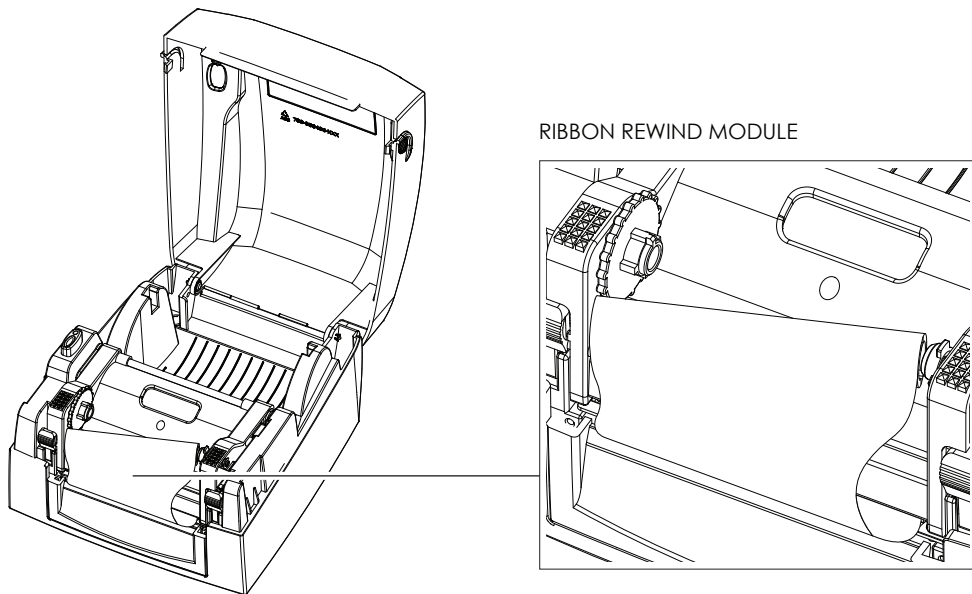

1. Place the right-hand side of empty ribbon core first.

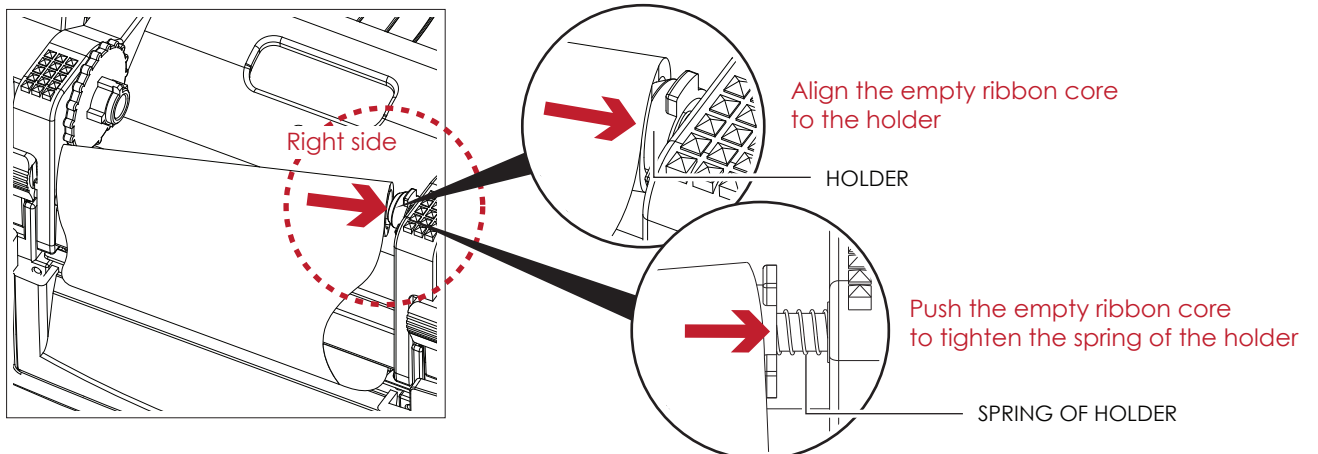

2 Printer Setup

2. Then place the left-hand side of the empty ribbon core.

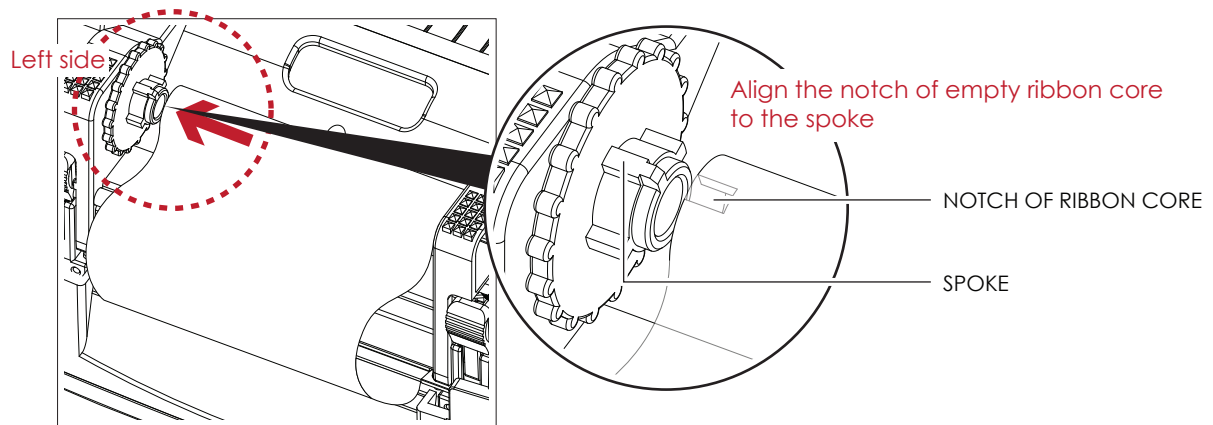

3. Turn the ribbon rewind wheel to tighten the ribbon until it has no wrinkles

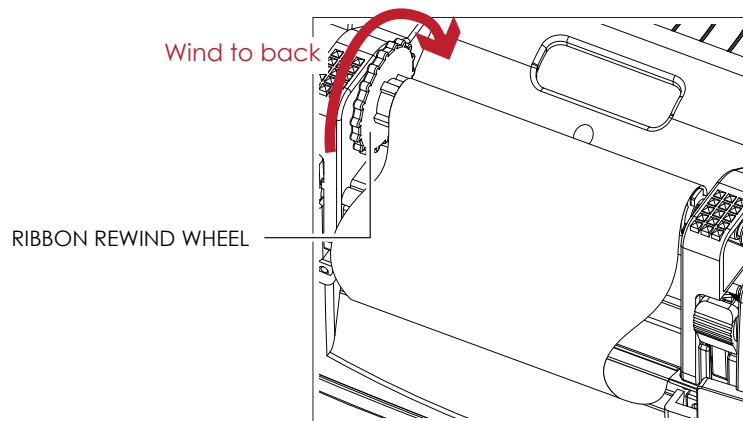

4. Ribbon loading completed.

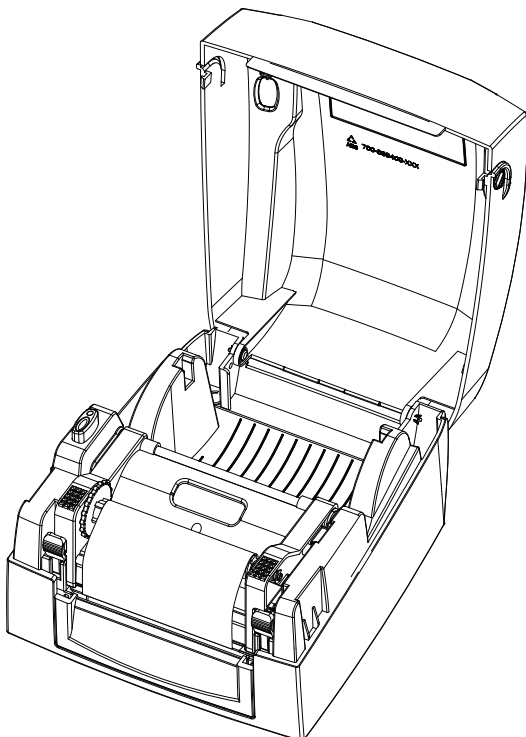

2 Printer Setup

2.4 Loading The Label Roll

A New Label Roll Module Installation

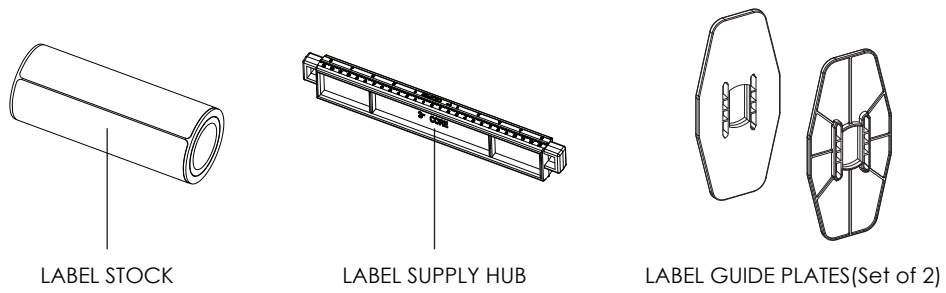

1. Place the label stock on the label supply hub, attach the label guide plates to the label stock holder.

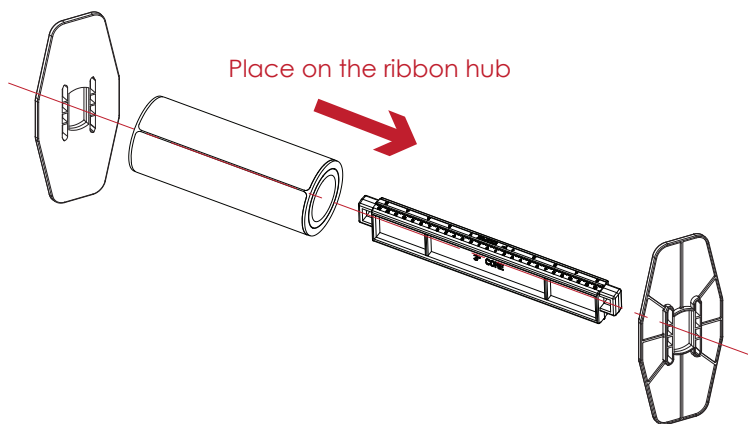

2. A label roll module is assembled as below.

A NEW LABEL ROLL MODULE

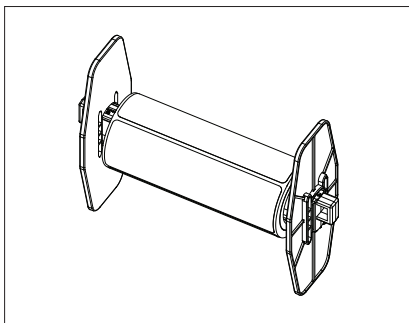

2 Printer Setup

Load The Label Roll Module On The Printer

1. Release the printing mechanism and lift it.

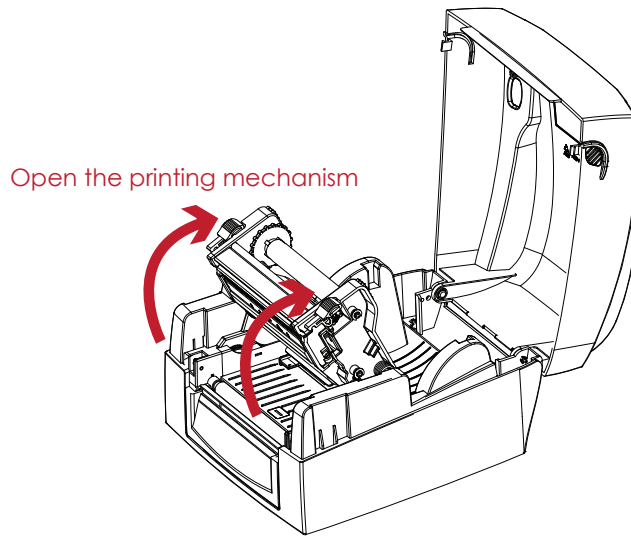

2. Place the label roll module on the printer.

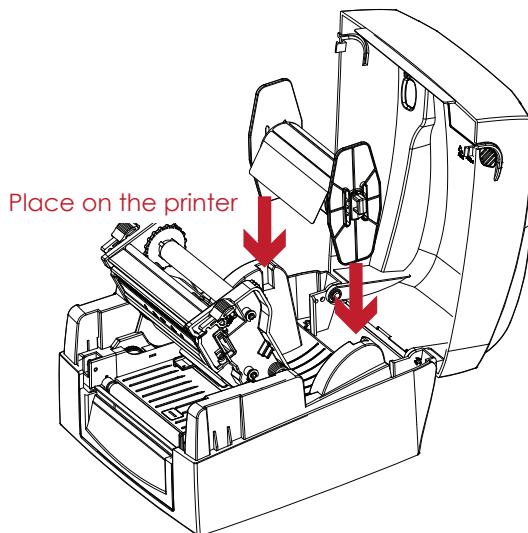

3. Pass the label through the printing mechanism.

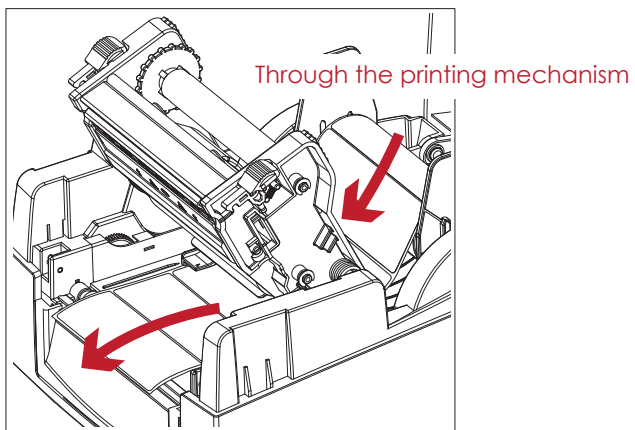

2 Printer Setup

4. Pass the label through the label guides and adjust the label guide to the label width. The label guide will help to prevent the label swaying.

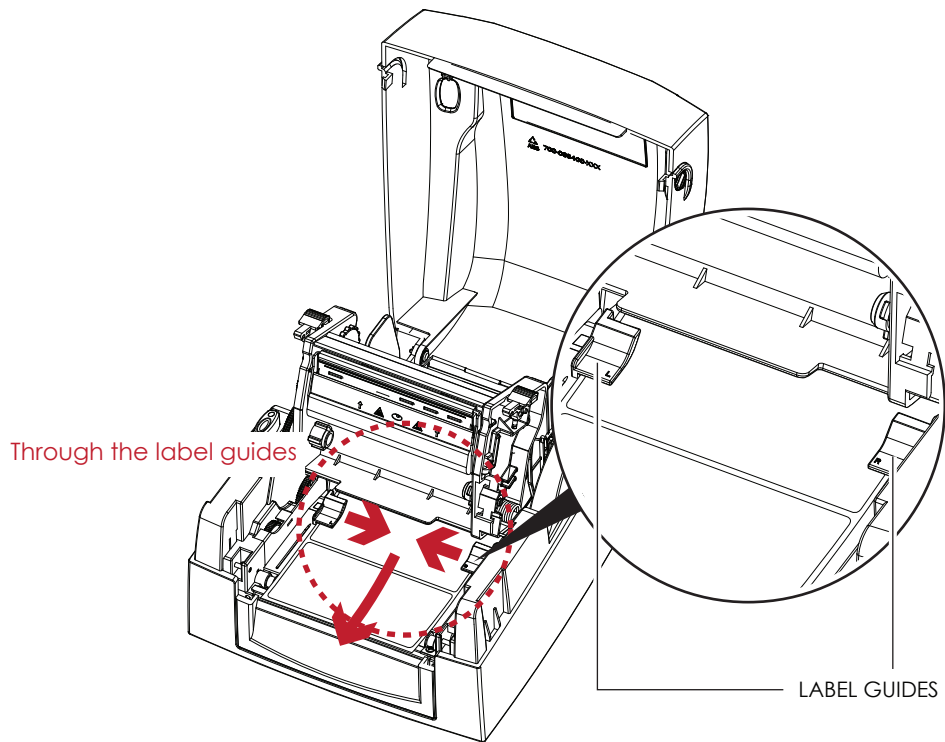

5. Close the printing mechanism and top cover to complete the label loading.

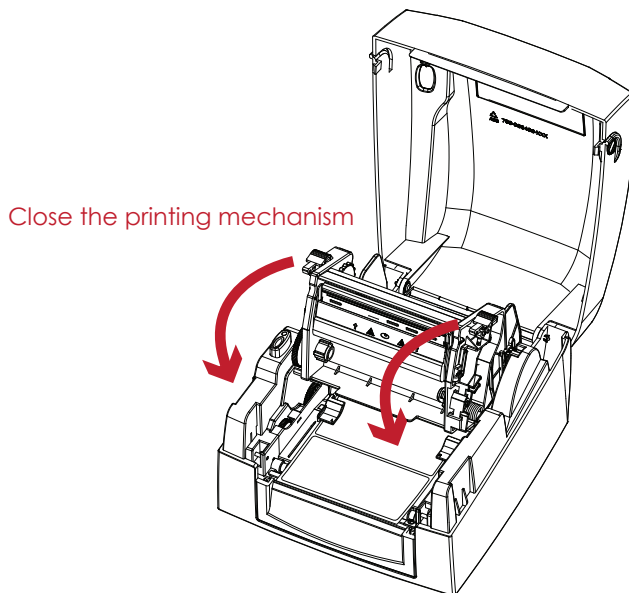

2 Printer Setup

2.5 Loading The Label Supply Hub

1" Cores

Loading the label supply hub for 1" cores.

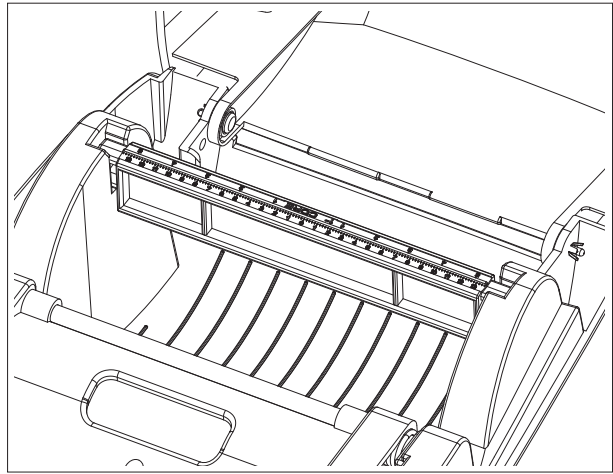
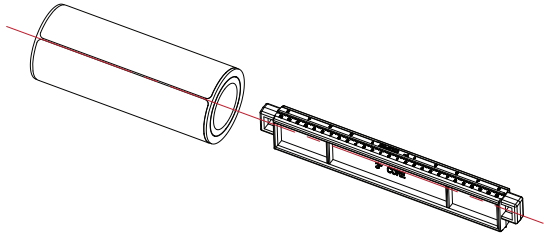

1.5" Cores

Loading the label supply hub for 1.5" cores.

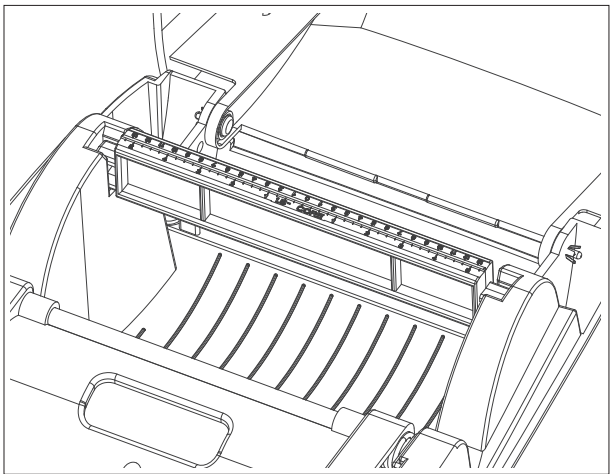
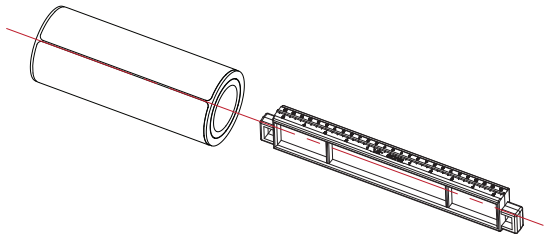

2 Printer Setup

2.6 Connecting The Printer To The Host Computer

1. Please make sure that the printer is switched off.
2. Connect the power cord to the AC adapter.

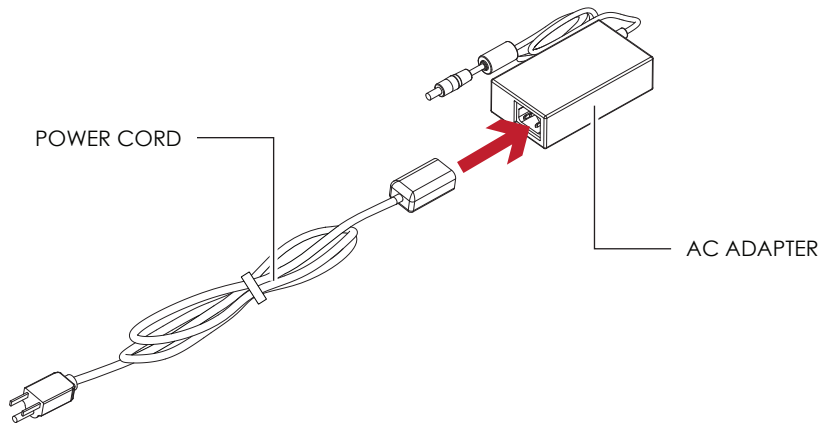

Connect the jack of the power adapter to the printer and connect the plug of the power adapter to the socket of the wall.

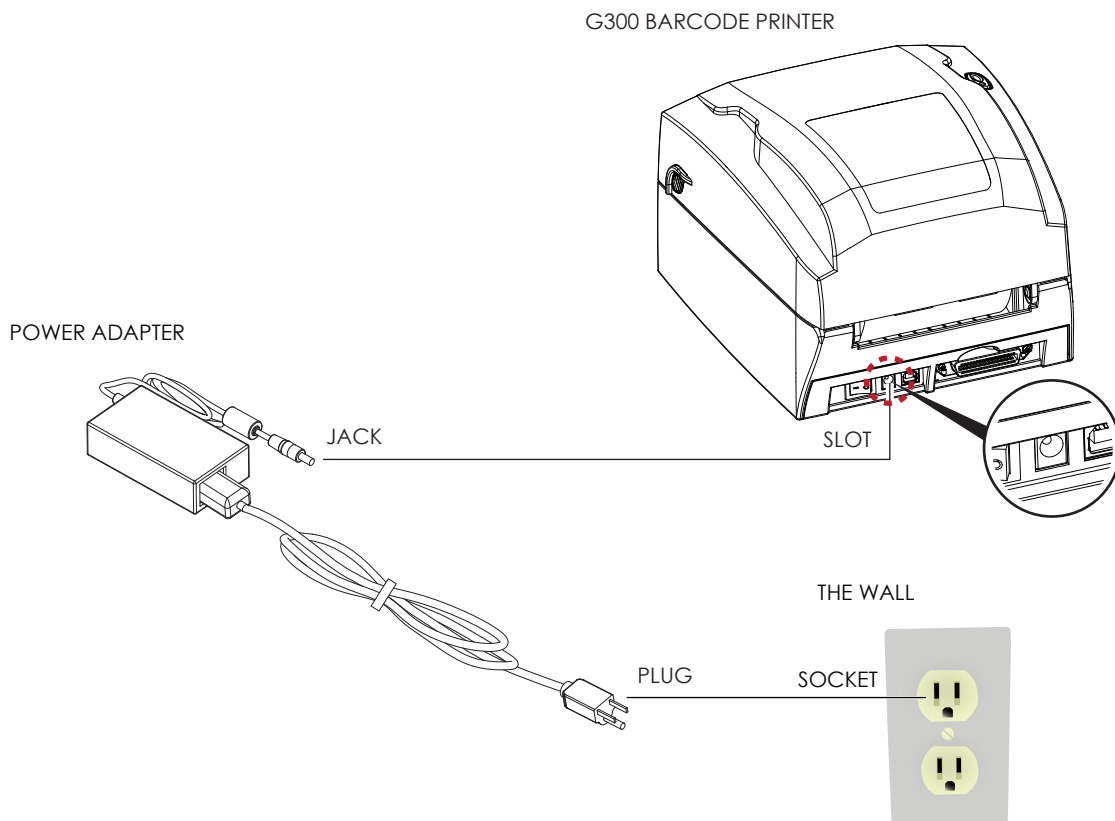

2 Printer Setup

3. Connect the USB/parallel cable to the printer and host computer.

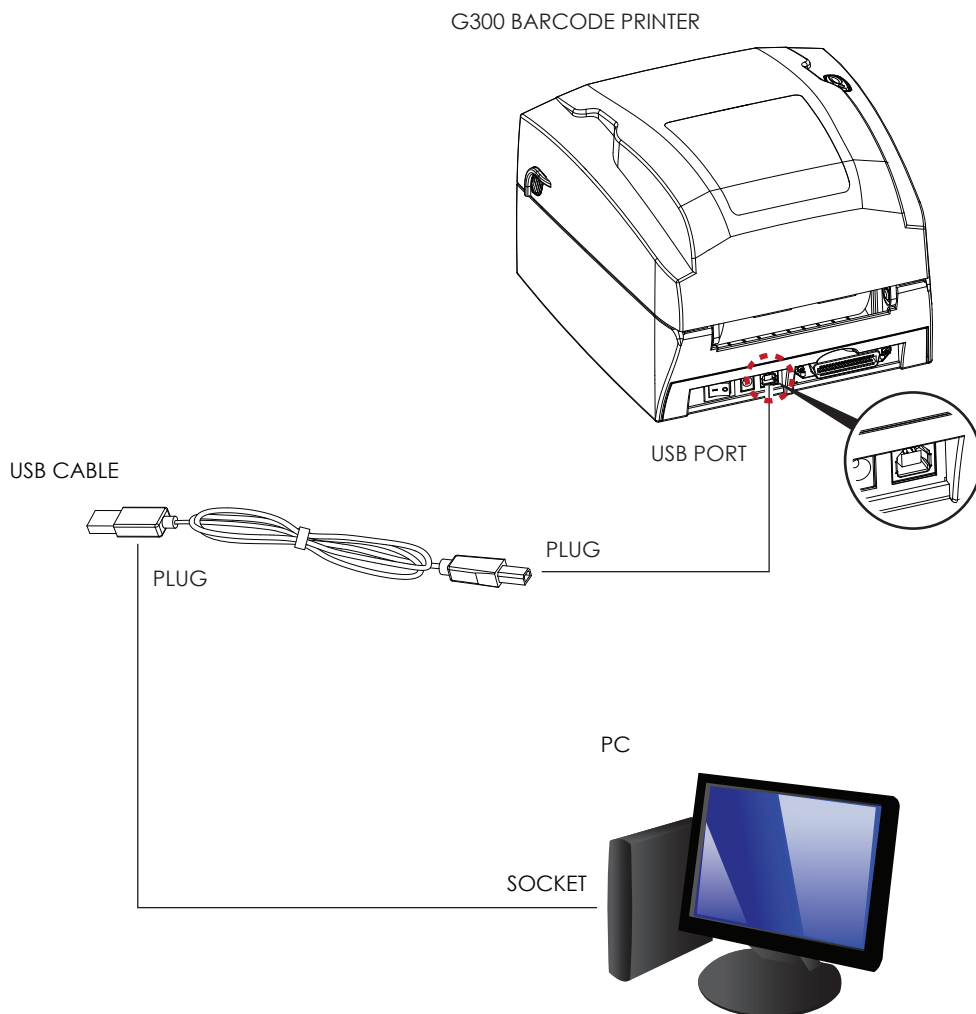

4. Switch on the printer. The LED indicator should now light up.

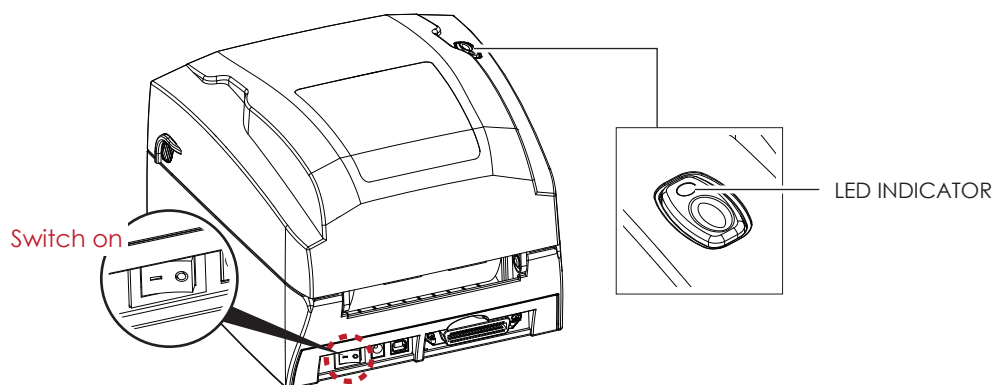

2 Printer Setup

2.7 Installing The Driver

1. Insert the product CD in the CD/DVD drive of the host computer and open the "Seagull Drivers" folder on the CD. Select the icon for the driver file and click it to start the installation.

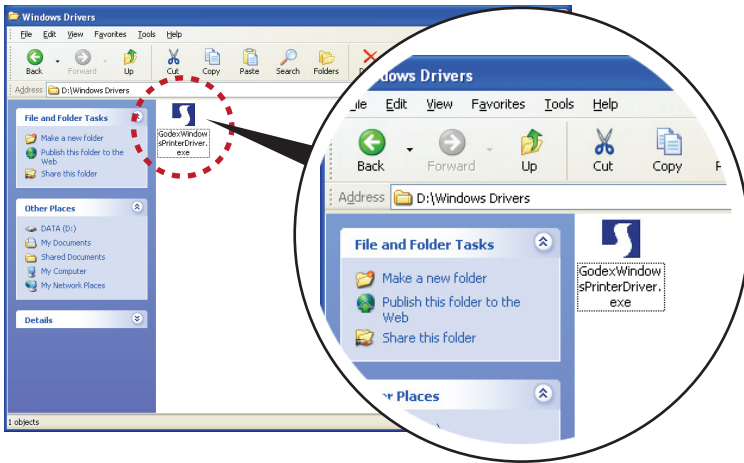

2. Follow the instructions on the screen. The Driver Wizard guides you through the installation procedure. Select "Install printer drivers".



3. Specify your printer model.

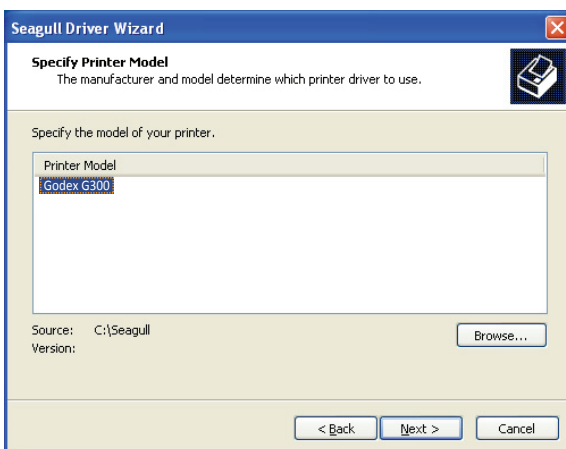

2 Printer Setup

- Specify the port used to connect the printer to the host computer.

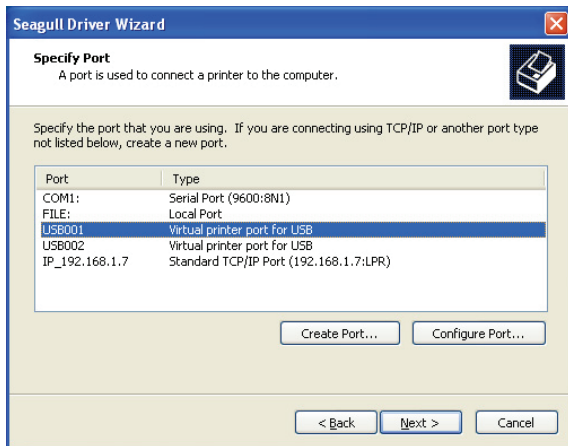

- Enter a printer name and assign the appropriate rights.

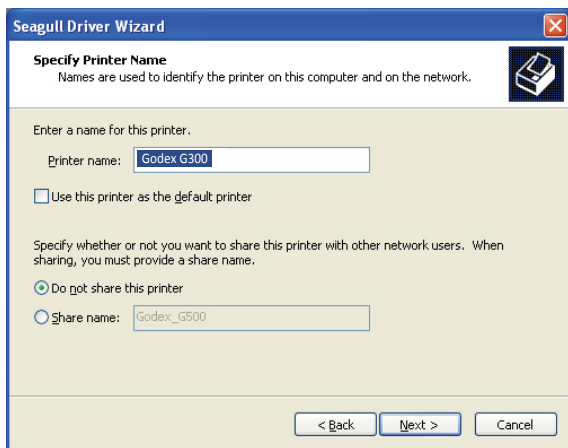

- Once the installation is complete, a summary of the printer settings is displayed. Check whether the printer settings are correct and click "Finish" to start copying the driver files. Wait until copying is complete, then finish the installation.



2 Printer Setup

7. Once the driver installation is complete, the new printer should appear in the "Printers and Faxes" folder.

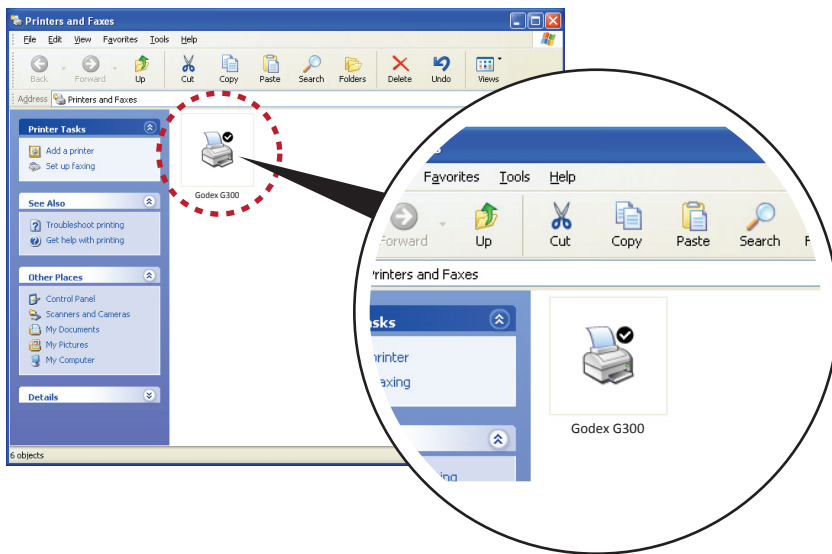

3 Operation Panel

3.1 LED Operation Panel

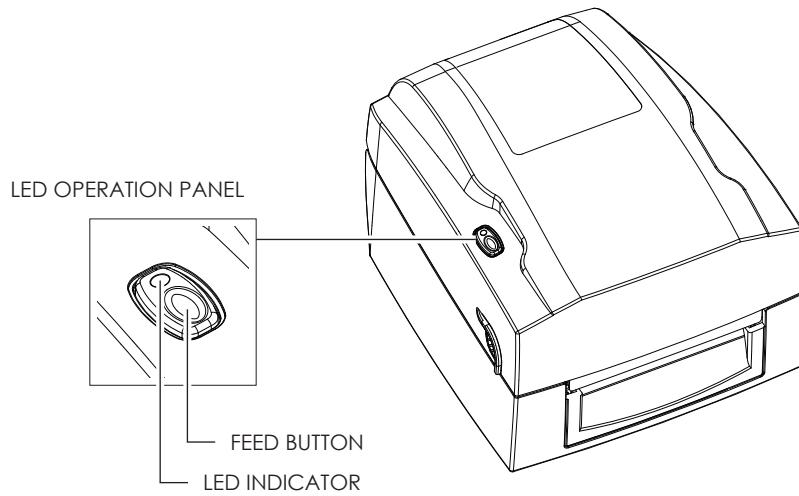

FEED Button

When you press the FEED button, the printer moves the label to the defined stop position.

If you are using continuous labels, pressing the FEED button will move label stock until you release the button again.

If you are using individual labels, pressing the FEED button will move only one label.

If the label does not stop at the correct position, you need to run the auto-detection function on the label stock, please see Section 3.3 Label Calibration and Self Test.

LED Indicators

LED Indicator	Status	Description
Green	Standby	The printer is ready for operation.
Red, Orange	Error	The printer has detected an error. See Section 3-2. Error Alerts.



3 Operation Panel

3.2 Error Alerts



In the event of a problem that prevents normal functioning of the printer, you will see an error message on LED indicators and hear some beep signals. Please refer to below table for the error alerts.

Error Light









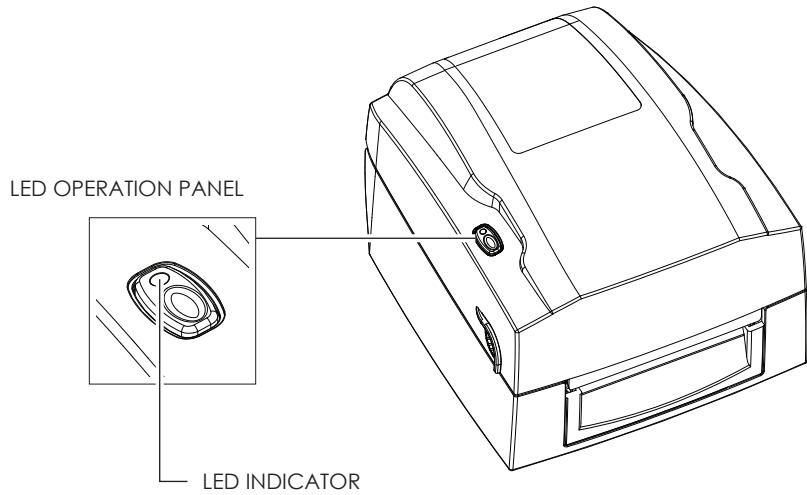

Colour

- Red 
- Orange 

Flashing Frequency

- Fast Flashing 
- Slow Flashing 
- Light On 



LED Indicator	Status	Description	Solution
 → 	Media Error	Unable to detect the paper.	Run the auto-detection function again.
 → 		The ribbon or labels are finished.	Replace the ribbon or label roll.
 → 	Settings Error	Paper jam.	Possible reasons: The paper feed roller is blocked. No gap or black mark could be detected.
 → 	Memory Error	No ribbon is loaded, but thermal transfer mode is selected as printing mode.	1. To work in thermal transfer mode, load a ribbon. 2. Alternatively, select the direct thermal printing mode.
		The memory is full. The printer also prints the message "Memory full".	Delete data you no longer need from the printer memory.
		Unable to find file. The printer also prints the message "Filename cannot be found".	Use the "~X4" command to print a list of all existing file names. Check whether the file name is correct.
	Print Head Error	File name already exists. The printer also prints the message "Filename is repeated".	Change the name of the file and try storing it on the printer again.
	Print Head Error	The print head temperature is too high.	Wait for the print head to cool down to operating temperature. The printer will then switch to standby mode and the LED will stop flashing.

3 Operation Panel

3.3 Label Calibration and Self Test

Label Calibration

The printer can automatically detect and store label height.
That means the host computer does not need to transmit the label height to the printer.

Self Test

Self-test function lets you check whether the printer is functioning normally.
Here is how you run the label size calibration and self test.

1. Check that the label stock is loaded correctly.
 2. Switch off the printer.
 3. Switch the printer on again, keeping the FEED button pressed. When the LED starts to flash red, release the FEED button. The printer will now measure the label stock and store the label height.
 4. Once the printer has successfully measured the label stock, it will print a self-test label.
- The contents of a self-test printout are listed below.

Model & Version	G300:GX.XXX
USB ID setting	USB S/N:12345678
Serial port setting	Serial port:96,N,8,1
MAC address of Ethernet port	MAC Addr:xx-xx-xx-xx-xx-xx
IP protocol setting	DHCP Enable
IP address of Ethernet port	IP xxx.xxx.xxx.xxx
Gateway setting	Gateway xxx.xxx.xxx.xxx
Netmask setting	Sub-Mask xxx.xxx.xxx.xxx
	#####
Number of DRAM installed	1 DRAM installed
Image buffer size	Image buffer size:1500 KB
Number of forms	0000 FORM(S) IN MEMORY
Number of graphics	0000 GRAPHIC(S) IN MEMORY
Number of fonts	000 FONT(S) IN MEMORY
Number of Asian fonts	000 ASIAN FONT(S) IN MEMORY
Number of Databases	000 DATABASE(S) IN MEMORY
Number of Scalable fonts	000 TTF(S) IN MEMORY
Free memory size	4073 KB FREE MEMORY
Speed, Density, Ref. Point, Print direction	^S4 ^H8 ^R000 ~R200
Label width, Form length, Stop position	^W102 ^Q100,3 ^E18
Cutter, Label Dispenser, Mode	Option:^D0 ^O0 ^AD
Sensor Setting	Reflective AD:1.96 2.84 2.49[0.88_23]
Code Page	Code Page:850
Printer is on factory default	Default state=Yes

4 NetSetting for Ethernet

4.1 Installing The NetSetting software

The NetSetting software is used to manage the network configurations when connecting the printer via Ethernet port. It is available on product CD or can be downloaded from official website. To install the NetSetting, please follow below steps.

1. Insert the product CD in the CD/DVD drive of the host computer and open the "Ethernet" folder on the CD.
2. Select the icon for the NetSetting installation file and click it to start the installation.

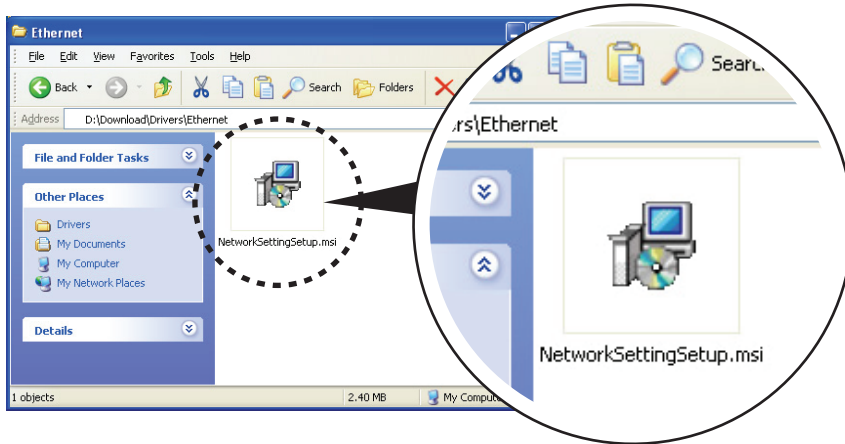

3. Follow the instructions on the screen. The Setup Wizard guides you through the installation procedure.
4. Specify the "Installation Folder".

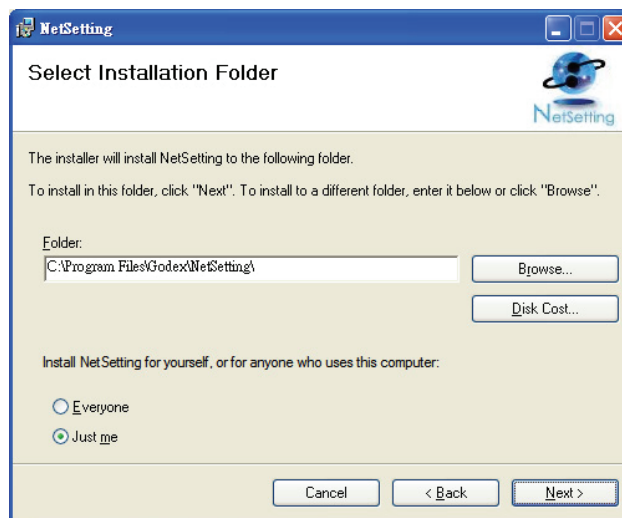

5. Click "Next" to start the installation.
6. Once the installation is completed; you will see the NetSetting icon on your desktop.

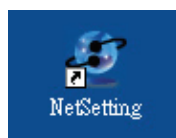

4 NetSetting for Ethernet

4.2 The Interface of NetSetting

Click the NetSetting icon to start the program; you will see the start page as below. The start page will display the basic information of connected printer and your PC.

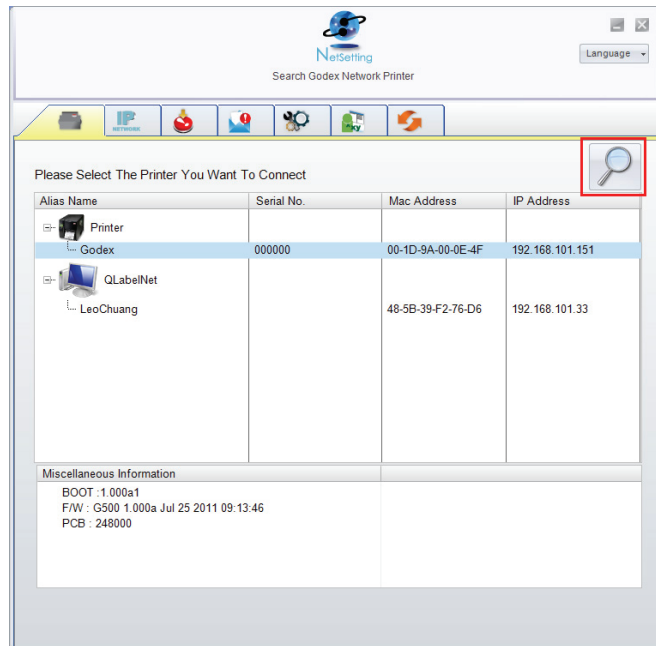

Click the magnifier icon to search the Godex printers which are connected via Ethernet port in your network environment. Once a connected Godex printer is detected, it will be listed on the start page.

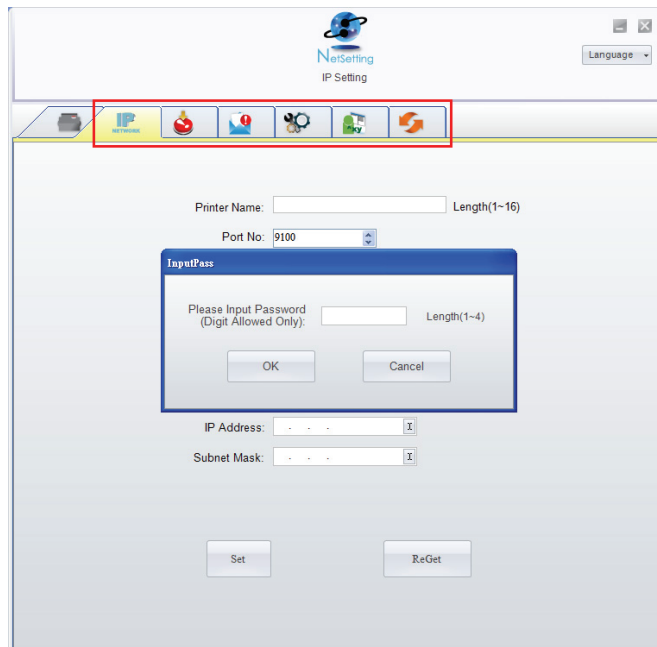

There are six tabs on the top of interface which can configure different types of network settings. But for the data security reason, you need correct password to enter the configuration pages.

Notice

* The default password is "1111", you can change the password later from the "IP Setting" tab.

4 NetSetting for Ethernet

IP Setting

The IP Setting tab can change the printer name, Port number, Gateway setting and the password for configuring the printer. You can also set the printer's IP address either by DHCP or by Static IP.

The screenshot shows the 'NetSetting IP Setting' window. The title bar includes the NetSetting logo and a 'Language' dropdown. The navigation bar contains icons for printer, IP Network, Home, Mail, Settings, and Refresh. The main content area has the following fields and options:

- Printer Name: Length(1~16)
- Port No:
- Default Gateway:
- Password: Length(1~4)
- Get IP From DHCP Server
- Static IP
- IP Address:
- Subnet Mask:
-

You can press "Set" button to apply the settings and "ReGet" button to refresh the setting values.

Notice

* To fully benefit from the NetSetting software, you should be familiar with basic networking principles. Please contact your network administrator for related network setting information.

4 NetSetting for Ethernet

Alert Path Setting

NetSetting will send the alert messages to designated mail account when the error happened on printer. The alert messages are sent by SMTP (Simple Mail Transfer Protocol) or SNMP (Simple Network Management Protocol). You can set or change the configurations of SMTP and SNMP on this "Alert Path Setting" tab.

Alert Path Setting

Language ▾

Printer IP Network Alert Settings Printer Status Refresh

SMTP Notification Enable

Login Account: Length(1~64)

Login Password: Length(1~16)

Server IP Address: xxx.xxx.xxx.xxx

Mail Subject: Length(1~60)

Mail From Address: Length(1~32)

Mail To Address: Length(1~32)

Duration Cycle: 0 ~ 168 Hours

Event Counter: 1 ~ 100

SNMP Notification Enable

SNMP Community: Length(1~16)

SNMP Trap Community: Length(1~16)

Trap IP Address: xxx.xxx.xxx.xxx

Set ReGet

You can press "Set" button to apply the settings and "ReGet" button to refresh the setting values.

4 NetSetting for Ethernet

Alert Message Setting

For the alert message notification function, you can decide which error cases need to be sent out to the operator. Moreover, the alert messages can be set to be sent by SMTP, SNMP or both.

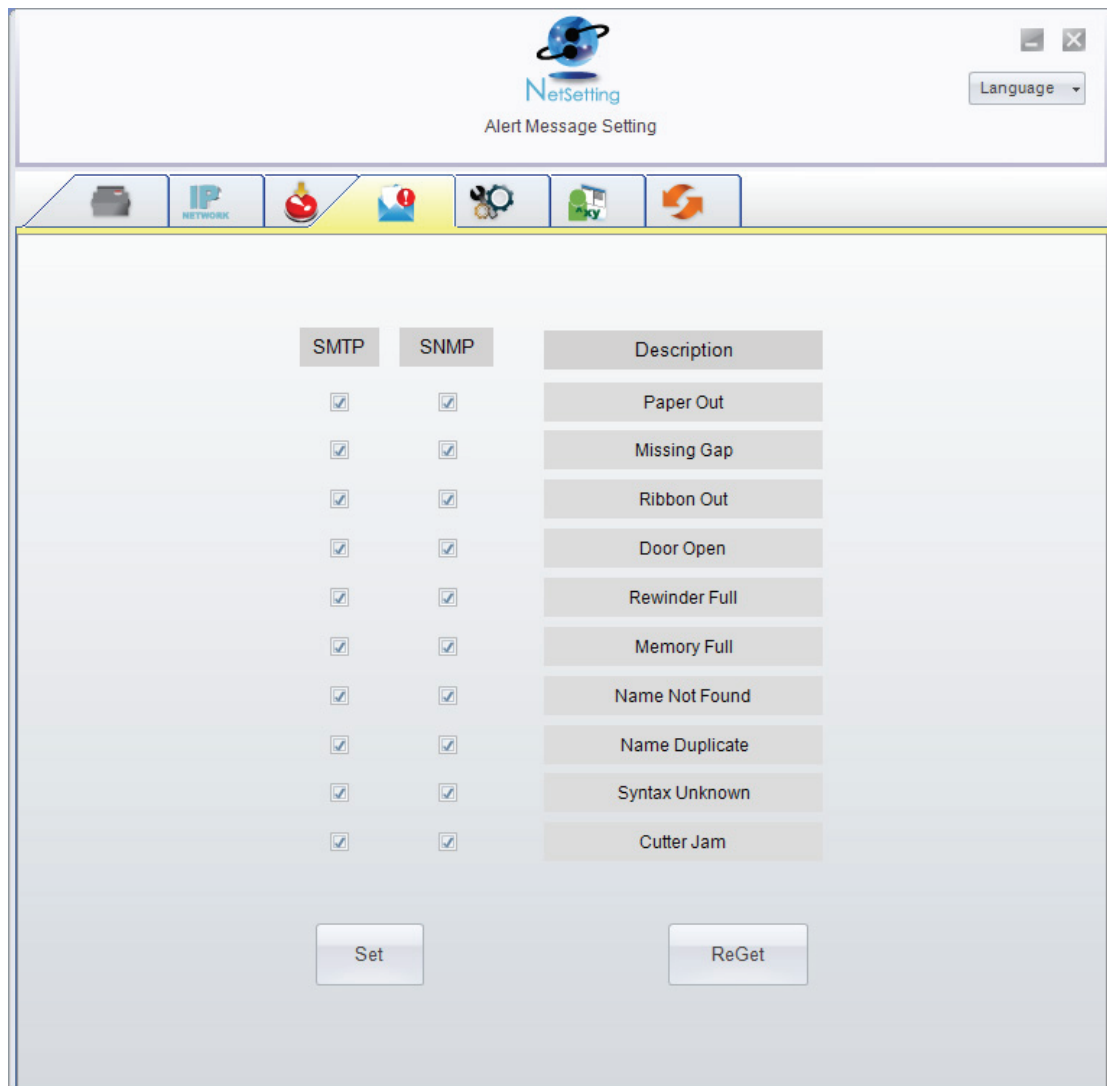

You can press "Set" button to apply the settings and "ReGet" button to refresh the setting values.

4 NetSetting for Ethernet

Printer Configuration

Set or change the configurations of connected printer. Most of key settings for the printer operation can be done by this setting page.

Printer Configuration

Language

Printer Setup

Printer Model	Resolution	Speed	Darkness	Stripper/Applicator	Labels per Cut	Printing Mode
G500	203	4	10	0 (None)	0	Thermal Transf

PC Com Port Settings

Baud Rate	9600
Parity	None
Data Bits	8
Stop Bits	1

Miscellaneous

LCD Language	Sensing Mode	2 - Automatic
Keyboard Language	Smart Backfeed	OFF
Code Page	Top Of Form	ON
Code Page 850	Buzzer	ON

Set ReGet

You can press "Set" button to apply the settings and "ReGet" button to refresh the setting values.

4 NetSetting for Ethernet

User Command

The "User Command" tab provides a communication interface for operator to control the printer. Input printer commands in "Input Command" window and press "Send Command" button, the commands will be sent to the printer.

For some commands that will return response message, the message will be displayed in "Output Message" window.

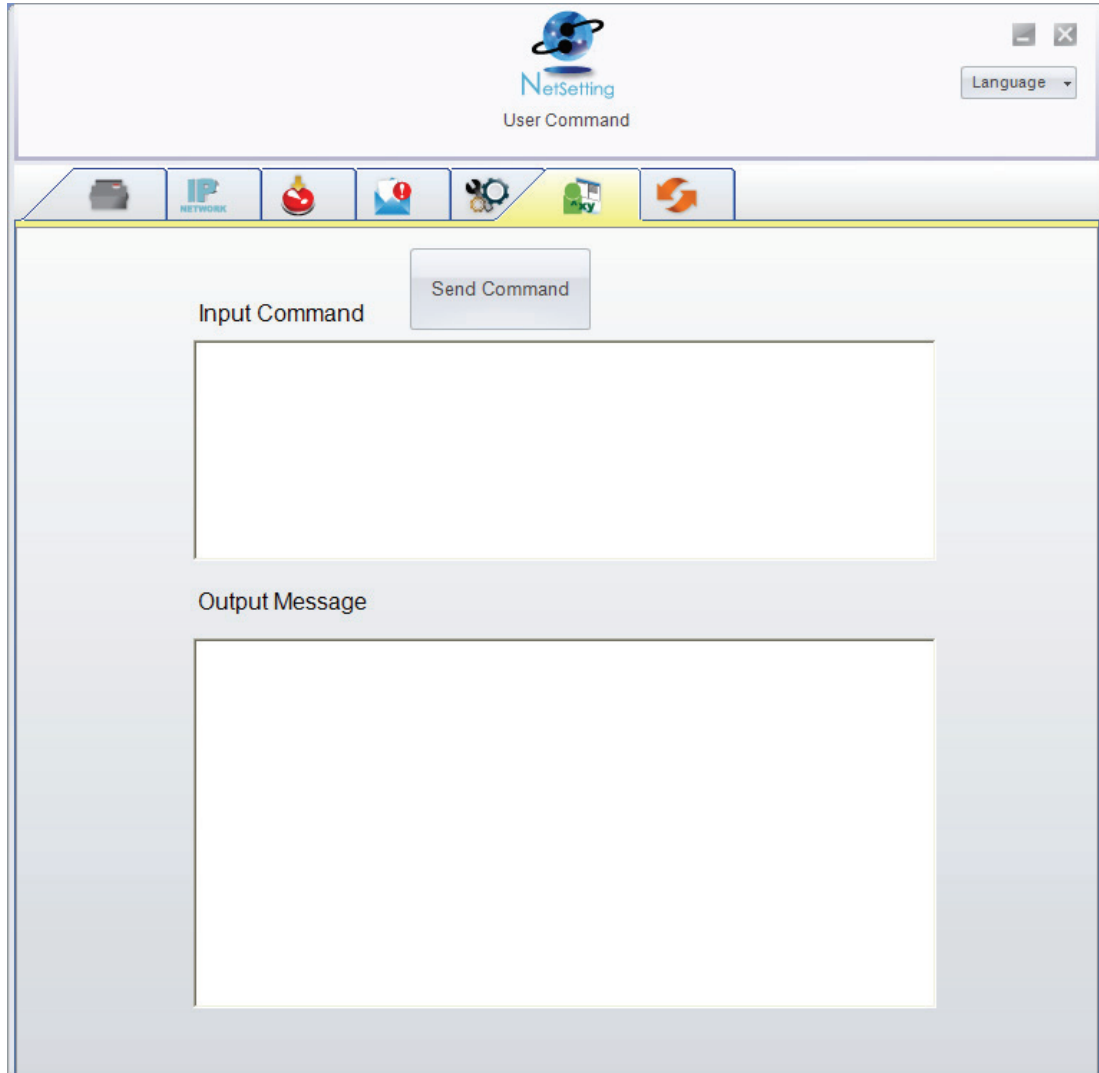

You can press "Send Command" button to send printer commands via Ethernet port and control the printer remotely.

4 NetSetting for Ethernet

Firmware Download

On "Firmware Download" tab, the current version of printer firmware will be showed on the screen. If you need to update the printer firmware, just specify the file location of firmware file and press "Start Download Firmware" button. The printer firmware then can be updated remotely.

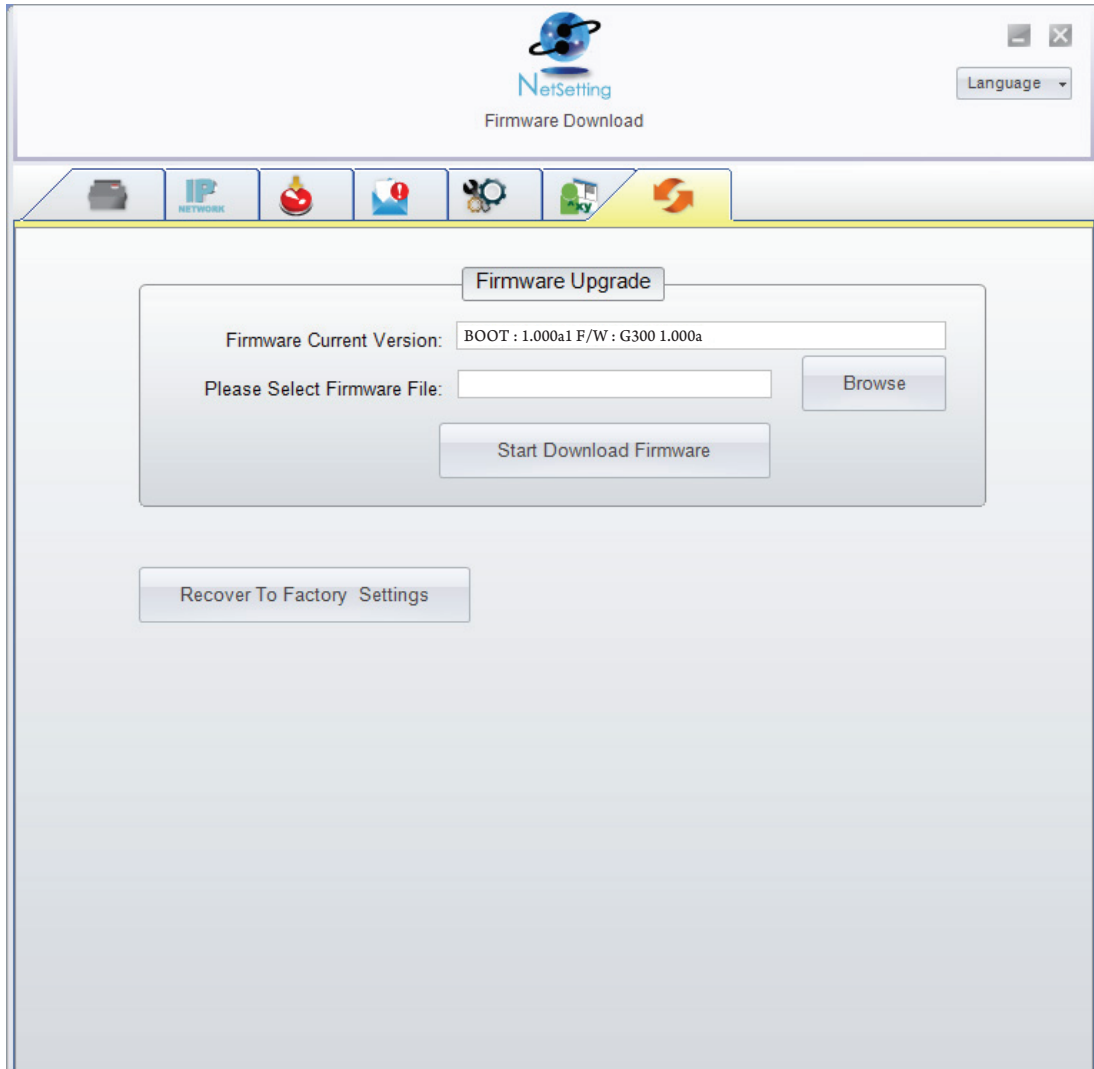

In addition to the firmware update, you can press "Recover To Factory Settings" button to restore the printer configurations back to factory default.

5 Maintenance And Adjustment

5.1 Cleaning The Print Head

Dirt on the print head or ribbon, or glue residue from the label stock may result in inadequate print quality. The printer cover must therefore always be closed during printing. Keeping dirt and dust away from the paper or labels ensures a good print quality and a longer lifespan of the print head.

Cleaning Steps

Here is how you clean the print head.

1. Switch off the printer.
2. Open the printer cover.
3. Release the printing mechanism and lift it.
4. Remove the ribbon.
5. To remove any label residue or other dirt from the print head (see red arrow), please use a soft lint-free cloth dipped in alcohol.

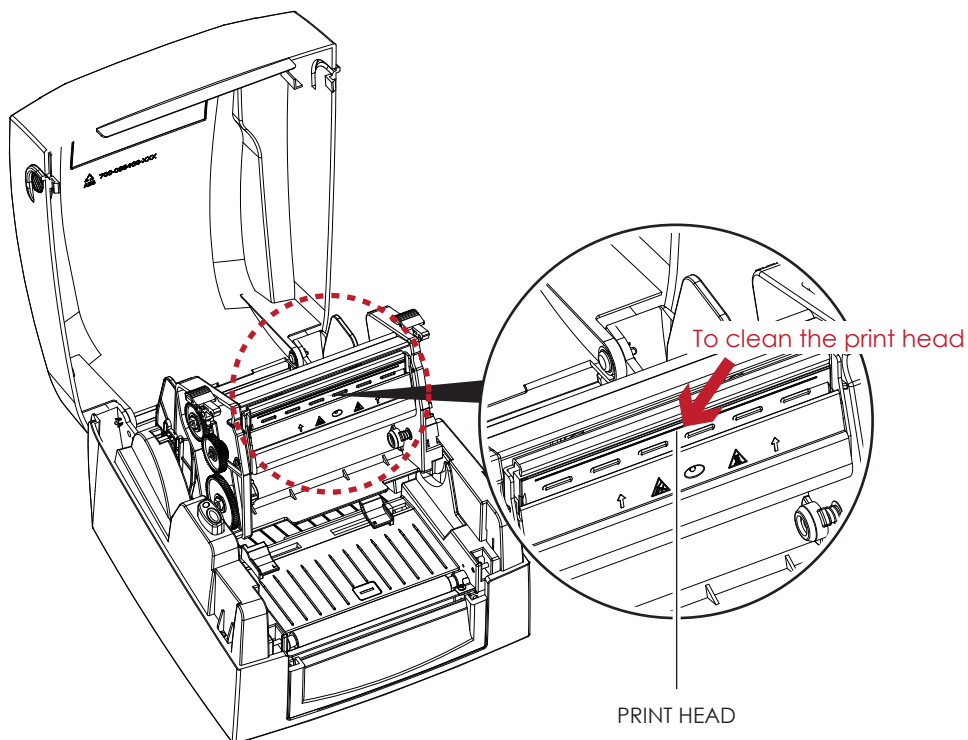

Notice

- * The print head should be cleaned once a week.
- * Please make sure that there are no metal fragments or other hard particles on the soft cloth used to clean the print head.

5 Maintenance And Adjustment

5.2 Adjusting The Print Head Pressure

When printing on special media (with varying material thickness), the print quality may suffer. You will then need to adjust the print head pressure.

Adjustment Steps

1. Open the printer cover.
2. Remove the ribbon.
3. Use a screw driver and slowly turn the adjustment screws for the print head to increase or reduce the print head pressure.

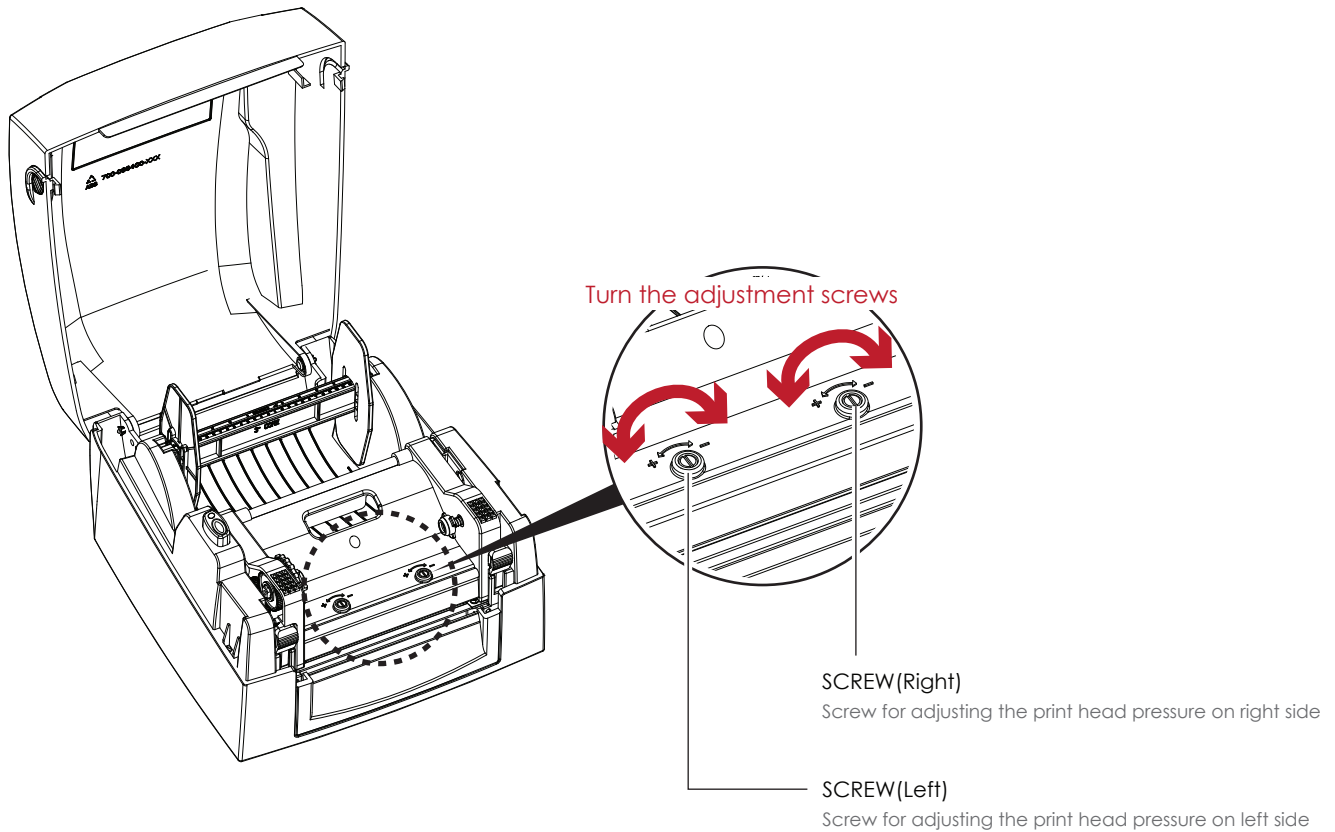

5 Maintenance And Adjustment

5.3 Adjusting The Print Line

When the print line is incorrectly set, the print quality on one side of the medium may suffer. In such a case, the print line must be adjusted so it is positioned parallel to the paper feed roller.

Adjustment Methods

1. To move the print head in Direction-A as indicated by the red arrow, turn the adjustment screw anticlockwise (see Arrow-1).
2. To move the print head in Direction-B as indicated by the red arrow, turn the adjustment screw clockwise (see Arrow-2).

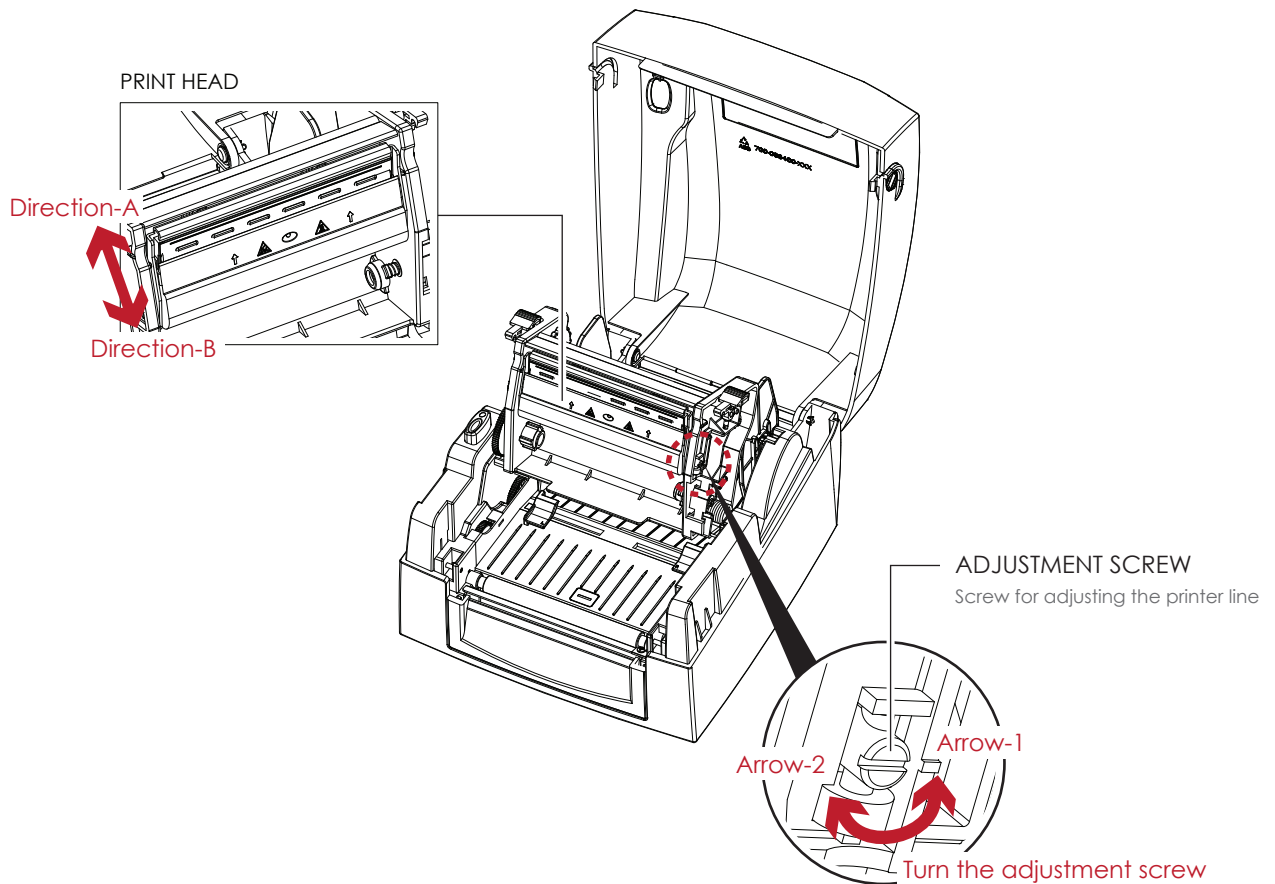

5 Maintenance And Adjustment

5.4 Troubleshooting

Problem	Solution
The printer is switched on but the LED does not light up.	<ul style="list-style-type: none">◆ Check the power supply. Please see the Section 2.6
The LED lights up red and printing is interrupted.	<ul style="list-style-type: none">◆ Check the software settings (driver settings) or command codes.◆ Look for the error alert in the table in Section 3.2. Error Alerts.◆ Check whether the print mechanism is closed correctly. Please see the Section 3.2
The label stock passes through the printer but no image is printed.	<ul style="list-style-type: none">◆ Please make sure that the label stock is loaded the right way up and that it is suitable material.◆ Choose the correct printer driver.◆ Choose the correct label stock and a suitable printing mode.
The label stock jams during printing.	<ul style="list-style-type: none">◆ Clear the paper jam. Remove any label material left on the thermal print head and clean the print head using a soft lint-free cloth dipped in alcohol. Please see the Section 5.1
There is no printed image on some parts of the label.	<ul style="list-style-type: none">◆ Check whether any label material or ribbon is stuck to the thermal print head.◆ Check for errors in the application software.◆ Check whether the starting position has been set incorrectly.◆ Check the ribbon for wrinkles.
There is no printed image on part of the label or the image is blurred.	<ul style="list-style-type: none">◆ Check the thermal print head for dust or other dirt.◆ Use the internal "~T" command to check whether the thermal print head will carry out a complete print job.◆ Check the quality of the print medium.
The printed image is positioned incorrectly.	<ul style="list-style-type: none">◆ Check whether there is paper or dust covering the sensor.◆ Check whether the label stock is suitable. Contact your supplier.◆ Check the paper guide settings.
A label is missed out during printing.	<ul style="list-style-type: none">◆ Check the label height setting.◆ Check whether there is dust covering the sensor.◆ Run the auto-detection function. Please see the Section 3.3
The printed image is blurred.	<ul style="list-style-type: none">◆ Check the darkness setting.◆ Check the thermal print head for dust or dirt. Please see the Section 5.1◆ Check if the ribbon is suitable for label stock.

Notice

* If any problems occur that are not described here, please contact your dealer.

APPENDIX

PRODUCT SPECIFICATIONS

Model		G300	G330
Print Method		Thermal Transfer/Direct Thermal	
Resolution		203dpi(8dots/mm)	300dpi(12dots/mm)
Print Speed		4IPS(102mm/s)	3IPS(76.2 mm/s)
Print Width		4.25"(108mm)	4.16"(105.7mm)
Print Length		Min. 0.16"(4mm)**; Max. 68"(1727mm)	Min. 0.16"(4 mm)**; Max. 30"(762mm)
Memory	Flash	8MB Flash(4MB for user storage)	
	SDRAM	16MB SDRAM	
Sensor Type		Fixed transmissive sensor Reflective sensor, central aligned	
Media	Types	Continuous form, gap labels, black mark sensing, and punched hole; label length set by auto sensing or programming	
	Width	1"(25.4mm)Min.-4.64"(118mm)Max.	
	Thickness	0.003"(0.06mm)Min.-0.008"(0.20mm)Max.	
	Label Roll Diameter	Max. 5"(127mm)	
	Core Diameter	1", 1.5"(25.4mm, 38.1mm)	
Ribbon	Types	Wax, wax/resin, resin	
	Length	360"(110m)	
	Width	1.18"Min-4.33"(30mm-110mm)Max	
	Ribbon Roll Diameter	1.57"(40mm)	
	Core Diameter	0.5"(12.7mm)	
Printer Language		EZPL, GEPL, GZPL auto switch	
Software	Label Design Software	QLabel-IV(for EZPL only)	
	Driver	Windows 2000, XP, Vista, 7, Windows Server 2003&2008	
	DLL	Windows 2000, XP and Vista	
Resident Fonts	Bitmap Fonts	6, 8, 10, 12, 14, 18, 24, 30, 16X26 and OCR A&B Bitmap fonts 90°, 180°, 270° rotatable, single characters 90°, 180°, 270° rotatable Bitmap fonts 8 times expandable in horizontal and vertical directions	
	Scalable Fonts	90°, 180°, 270° rotatable	
Download Fonts	Bitmap Fonts	Bitmap fonts 90°, 180°, 270° rotatable, single characters 90°, 180°, 270° rotatable	
	Asian Fonts	Asian fonts 90°, 180°, 270° rotatable and 8 times expandable in horizontal and vertical directions	
Barcodes	Scalable Fonts	Scalable fonts 90°, 180°, 270° rotatable	
	1-D Bar codes	Code 39, Code 93, EAN 8/13(add on 2 & 5), UPC A/E(add on 2&5), I 2 of 5&I 2 of 5 with Shipping Bearer Bars, Codabar, Code 128(subset A, B, C), EAN 128, RPS 128, UCC 128, UCC/EAN-128 K-Mart, Random Weight, Post NET, ITF 14, China Postal Code, HIBC, MSI, Plessey, Telepen, FIM and GS1 DataBar	
	2-D Bar codes	PDF417, Datamatrix code, MaxiCode, QR code, Micro PDF417, Micro QR code and Aztec code	
Code Pages		CODEPAGE 437, 850, 851, 852, 855, 857, 860, 861, 862, 863, 865, 866, 869, 737 WINDOWS 1250, 1251, 1252, 1253, 1254, 1255, 1257 Unicode UTF8, UTF16	
Graphics		Resident graphic file types are BMP and PCX, other graphic formats are downloadable from the software	
Interfaces		Serial port: RS-232(DB-9) USB2.0 Ethernet 10/100Mbps print server	
Control Panel		One Tri-color LED: Power(Green, Orange and Red) Function Key: FEED	
Power		Auto Switching 100-240VAC, 50-60Hz	

APPENDIX

PRODUCT SPECIFICATIONS

Model		G300	G330
Environment	Operation Temperature	41°F to 104°F(5°C to 40°C)	
	Storage Temperature	-4°F to 122°F (-20°C to 50°C)	
Humidity	Operation	30-85%, non-condensing	
	Storage	10-90%, non-condensing	
Agency Approvals		CE(EMC), FCC Class A, CB and CCC	
Dimension	Length	10"(254mm)	
	Height	6.7"(170mm)	
	Width	8.8"(224mm)	
Weight		5.5 lbs (2.5Kg) ,excluding consumables	
Options		USB Device + Parallel interfaces(factory install) External label roll holder for 10"(250mm) O.D. label rolls External label rewinder	

Notice

- * Specifications are subject to change without notice. All company and/or product names are trademarks and/or registered trademarks of their respective owners.
- ** Minimum print height specification compliance can be dependent on non-standard material variables such as label type, thickness, spacing, liner construction, etc. Godex is pleased to test non-standard materials for minimum height printing capability.

APPENDIX

INTERFACE

Pinout Description

- USB

Connector Type : Type B

Pin NO.	1	2	3	4
Function	VBUS	D-	D+	GND

- Serial Port

Default settings : Baud rate 9600, no parity, 8 data bits, 1 stop bit, XON/XOFF protocol and RTS/CTS

RS232 Housing(9-pin to 9-pin)		
DB9 Socket		DB9 Plug
-	1	+5V, max 500mA
RXD	2	TXD
TXD	3	RXD
DTR	4	N/C
GND	5	GND
DSR	6	RTS
RTS	7	CTS
CTS	8	RTS
RI	9	N/C
Computer		Printer

- Parallel Port

Factory option

Handshaking : DSTB is sent to the printer, BUSY to the host computer.
 Interface Cable : Parallel cable compatible with IBM computers.
 Pinout : See below.

Pin NO.	Function	Transmitter
1	/Strobe	host / printer
2-9	Data 0-7	host
10	/Acknowledge	printer
11	Busy	printer
12	/Paper empty	printer
13	/Select	printer
14	/Auto-Linefeed	host / printer
15	N/C	
16	Signal Gnd	
17	Chasis Gnd	
18	+5V,max 500mA	
19-30	Signal Gnd	host
31	/Initialize	host / printer
32	/Error	printer
33	Signal Ground	
34-35	N/C	
36	/Select-in	host / printer

Notice

* The total current to the serial port may not exceed 500mA.